

HGI Part No.
999-675-1818

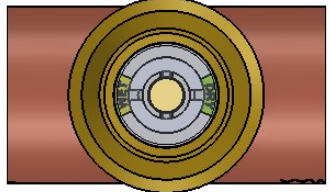

Label Orientation
标签方向

REV. 版本	ENC 工程变更通知	Description 变更描述	Name 变更人	Date 变更日期
B	ECN-HT18030	Item 2 to 6 updated, Leak test pressure 6MPa was 5.46MPa, 24.7 was 24.	Nancy Huang	6/22/2018

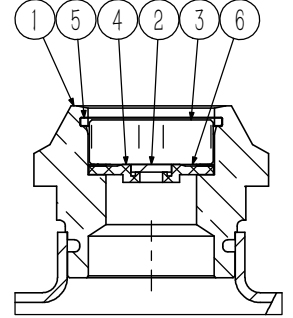
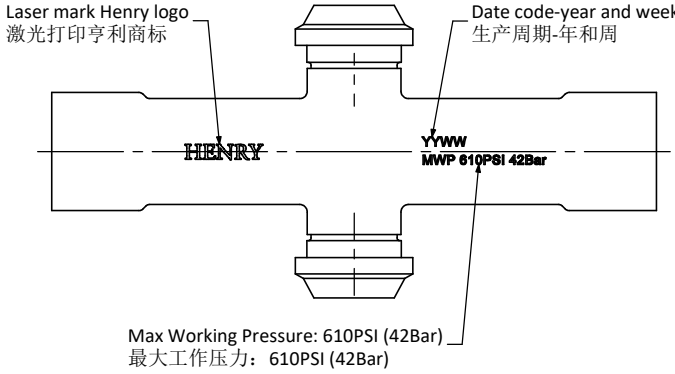
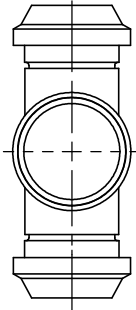
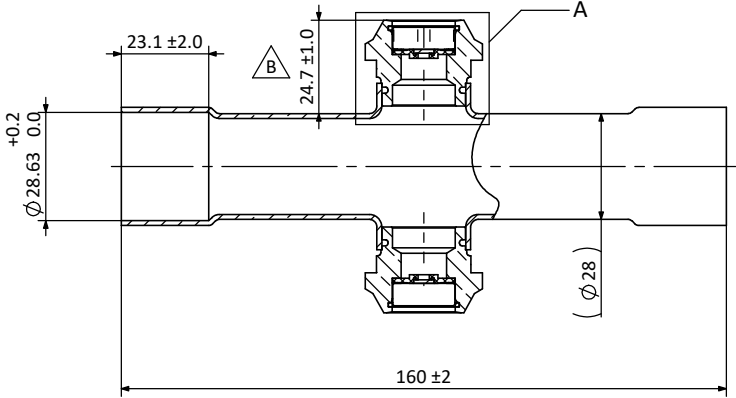

Detail A
Scale 1 : 1

- Technical Requirements:**
技术要求:
- Safe working pressure 4.2MPa; 安全工作压力为4.2MPa;
 - Leak test pressure 6MPa; 泄漏测试压力为6MPa;
 - Burst pressure 12.6MPa; 爆破压力为12.6MPa;
 - Operating temperature range of -50°C to +85°C; 操作温度范围为-50°C ~ +85°C;
 - Use roll form to crimp the glass; 用旋铆缩口方式来铆合镜片;
 - No cracks or dirt on roll form surface; 铆合面不得有裂纹夹渣等缺陷;
 - Manufacture to AS/NZS 5149.2. 制造标准为 AS/NZS 5149.2.

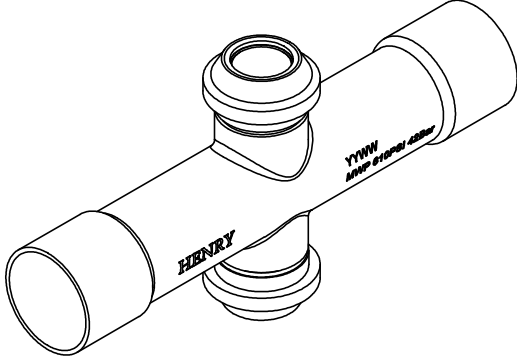

ISO 1:2

Item 序号	WMC MMN 孟氏物料编号	HGI Part No. 亨利物料编号	Description 描述	Material 材质	QTY 数量
6	030605016	PL-110-42	Indicator Label 视液镜标签	Paper	2
5	030309005	932-SG-187	Sight Glass Gasket Ø18.7mm 视液镜密封胶圈	Teflon	2
4	030301002	925-083	Mounting Disc 支架	PA66	2
3	030509036	899-SG-164	Ø 16.4mm Glass 视液镜片	Soda Glass Toughened	2
2	030509191	899-SG-54	Ø 5.4mm Indicator Paper, T=1.0mm 视液镜试纸	Paper	2
1	030501075	744-675-1818H	Sight Glass Sub-Assembly (Dual Port) 视液镜组件 1 1/8" (双视液镜)	Refer Table	1

Description 产品名称		Hermetic Sight Glass Assembly 1 1/8" (Dual Port) 视液镜装配 1 1/8" (双视液镜)		
Drawing No. 图纸编号	M030509065	REV 版次	B	
Material Master No. 物料编号	030509065	Drawing Size 图幅	A4	
Material 材质	Refer Table	Sheet Number 页码	1/1	
Attribute 属性	1 1/8"	Third Angle Projection 第三视角		

Linear Dimensions 线性尺寸	0 Decimal Place 整数	1 Decimal Place 1位小数	2 Decimal Place 2位小数	Angular Dimensions 角度尺寸	0 Decimal Place 整数	1 Decimal Place 1位小数	Estimated Weight 预估重量	298.3 g
	±1.0	±0.2	±0.05		±2°	±0.5°		
Tolerance Unless Stated Otherwise 未注尺寸公差								
Unit 绘图单位: mm								

Approved_by 批准	Julian Parker	6/27/2018
Checked_by 审核	Leo Wu	6/27/2018
Drawn_by 绘图	Nancy Huang	6/22/2018

