

HGI Part No.	30/05/2019 HENRY JTP <i>silke</i> APPROVED DOCUMENT	<input checked="" type="checkbox"/> PED 2014/68/EU	<input checked="" type="checkbox"/> AS2971.2	<input checked="" type="checkbox"/> UL207	REV. 版本	ENC 工程变更通知	Description 变更描述	Name 变更人	Date 变更日期
S-6311-customer		<input type="checkbox"/> CAT I	<input type="checkbox"/> CAT II						
		Volume Ltrs	Shell ID mm	Design Pressure MPa	Leak Test Pressure MPa	Proof Test Pressure MPa	Min Burst Test Pressure MPa		
		0.69	Ø72	3.1	3.1	3.1	15.5		

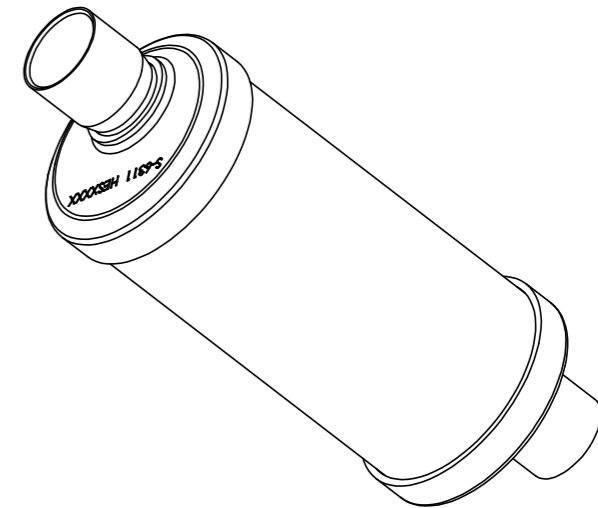

ISO 1:2.5

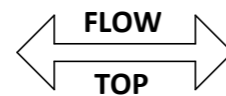

Stamp manufactory code and date code
冲印工厂代码和制造日期

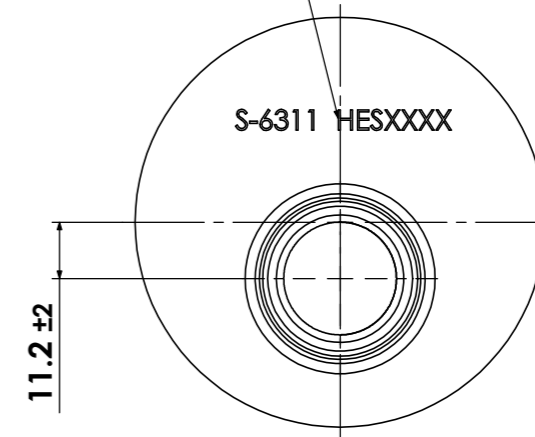
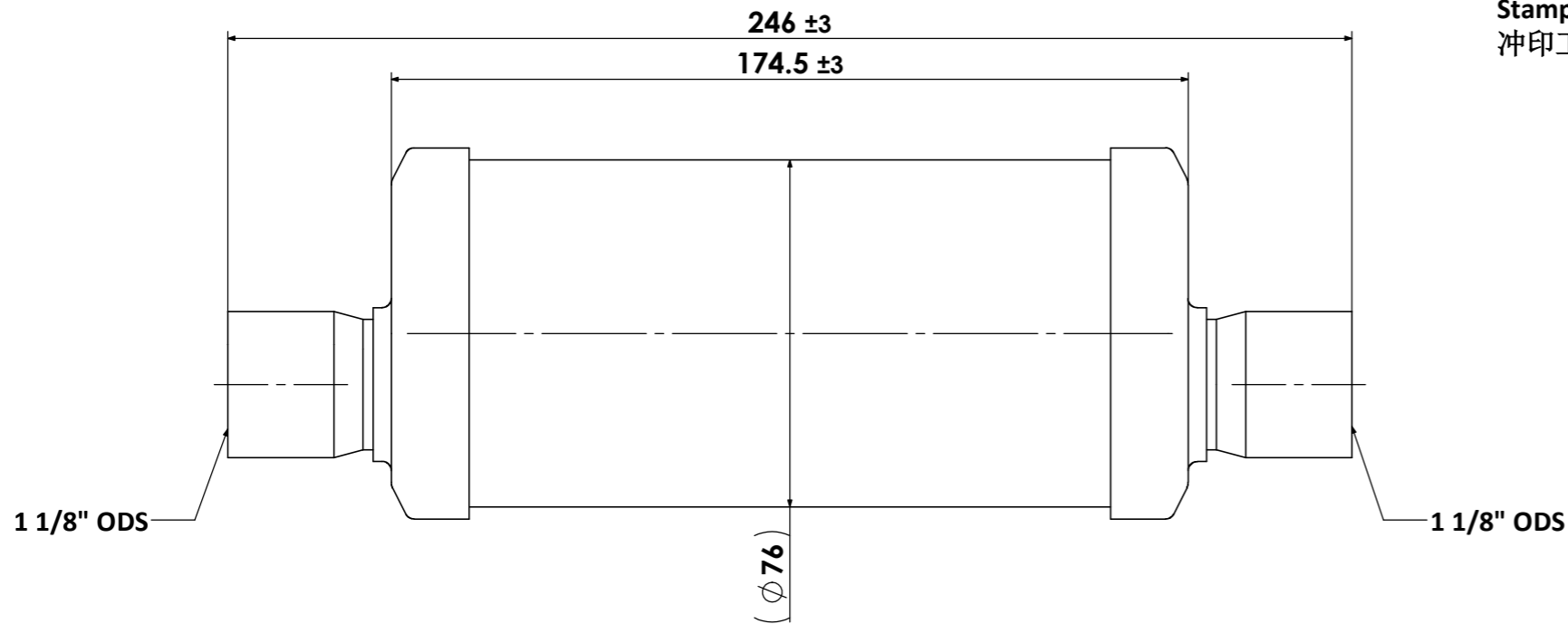

Technical Requirements:
技术要求

1. Allowable operating temperature 0°C to +121°C;
工作温度0°C到+121°C;
2. Powder coating: Henry Blue RAL 5013.
喷涂颜色: 亨利蓝RAL 5013。

Description 产品名称	Muffler 消音器		
Drawing No. 图纸编号	M050509910	REV 版次	A
Material Master No. 物料编号	050509910	Drawing Size 图幅	A3
Material 材质	N/A	Sheet Number 页码	1/1
Attribute 属性	1 1/8" ODS	Third Angle Projection 第三视角	

Dimensions inside an oval are critical dimensions 椭圆内尺寸为关键尺寸	Linear Dimensions 线性尺寸 (mm)	0 Decimal Place 整数	1 Decimal Place 1位小数	2 Decimal Place 2位小数	Angular Dimensions 角度尺寸	0 Decimal Place 整数	1 Decimal Place 1位小数	Ra 1.6	Estimated Weight 预估重量	N/A	Approved_by 批准	Julian Parker	2019/5/30
		±1.0	±0.2	±0.05		±2°	±0.5°		Scale 比例	1:1.5	Checked_by 审核	Leo Wu	2019/5/30
Tolerance Unless Stated Otherwise 未注尺寸公差									Unit 绘图单位	mm	Drawn_by 绘图	Nancy Huang	2018/9/19

