

|                                 |             |  |                        |  |                             |              |                           |                                      |                         |                        |
|---------------------------------|-------------|--|------------------------|--|-----------------------------|--------------|---------------------------|--------------------------------------|-------------------------|------------------------|
| HGI Part No.<br>S-6411-customer |             | 05/07/2021 HENRY<br>JTP<br>APPROVED DOCUMENT |                        | <input checked="" type="checkbox"/> PED 2014/68/EU<br><input type="checkbox"/> CAT I <input checked="" type="checkbox"/> CAT II <b>B</b><br><input checked="" type="checkbox"/> AS2971.2 <input checked="" type="checkbox"/> UL207 |                             | REV. 版本<br>B | ECN 工程变更通知<br>ECN-HT21017 | Description 变更描述<br>CAT II WAS CAT I | Name 变更人<br>Angel Zhang | Date 变更日期<br>2021/6/11 |
| Volume Ltrs                     | Shell ID mm | Design Pressure MPa                          | Leak Test Pressure MPa | Proof Test Pressure MPa  | Min Burst Test Pressure MPa |              |                           |                                      |                         |                        |
| 1.7                             | ∅97         | 3.1  | 3.1                    | 4.43   | 15.5                        |              |                           |                                      |                         |                        |

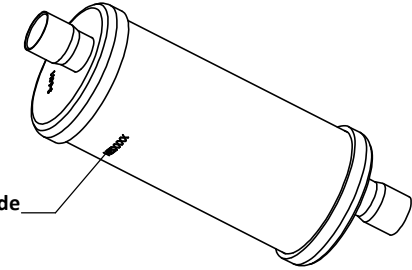

Stamp manufactory code and date code  
冲印工厂代码和制造日期

ISO 1:4

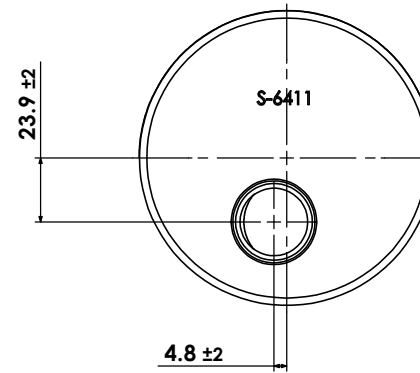
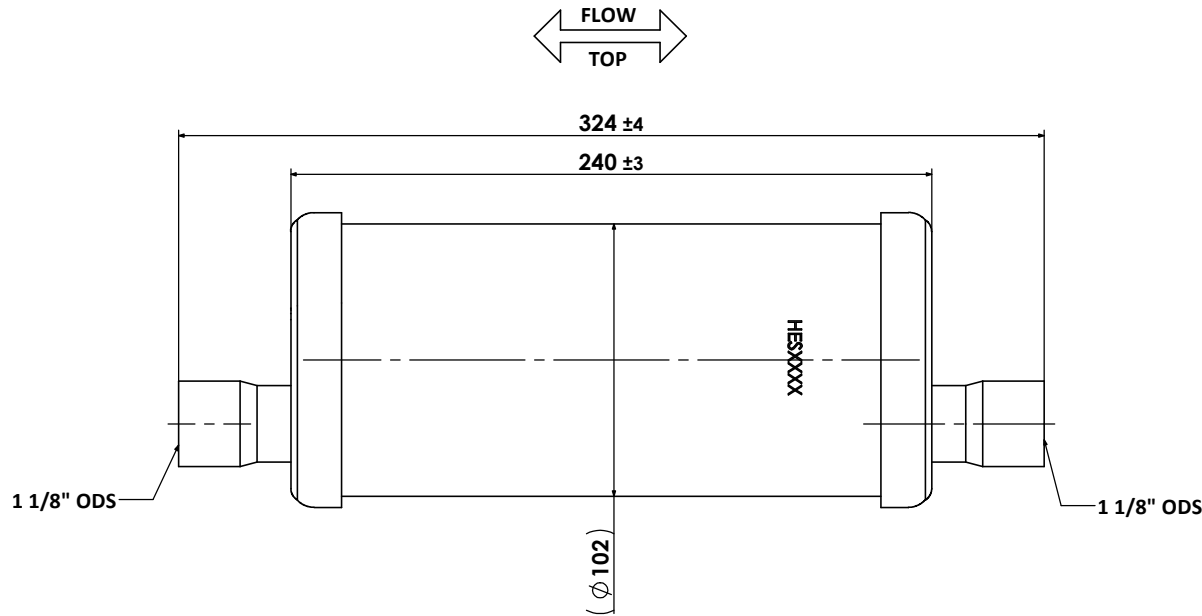

**Technical Requirements:**  
技术要求

- Allowable operating temperature 0°C to +121°C;  
工作温度0°C到+121°C;
- Powder coating: Henry Blue RAL 5013.  
喷涂颜色: 亨利蓝RAL 5013.

|                          |               |                             |     |  |
|--------------------------|---------------|-----------------------------|-----|--|
| Description 产品名称         |               | Muffler 消音器                 |     |  |
| Drawing No. 图纸编号         | M050509913    | REV 版本                      | B   |  |
| Material Master No. 物料编号 | 050509913     | Drawing Size 图幅             | A3  |  |
| Material 材质              | N/A           | Sheet Number 页码             | 1/1 |  |
| Attribute 属性             | 1 1/8" ODS    | Third Angle Projection 第三视角 |     |  |
| Approved_by 批准           | Julian Parker | 2019/5/30                   |     |  |
| Checked_by 审核            | Leo Wu        | 2019/5/30                   |     |  |
| Drawn_by 绘图              | Nancy Huang   | 2018/9/19                   |     |  |

|   |                       |                         |                         |                            |                       |                         |                 |                          |     |             |     |              |    |
|---|-----------------------|-------------------------|-------------------------|----------------------------|-----------------------|-------------------------|-----------------|--------------------------|-----|-------------|-----|--------------|----|
| Linear Dimensions<br>线性尺寸 (mm)              | 0 Decimal Place<br>整数 | 1 Decimal Place<br>1位小数 | 2 Decimal Place<br>2位小数 | Angular Dimensions<br>角度尺寸 | 0 Decimal Place<br>整数 | 1 Decimal Place<br>1位小数 | Ra $\sqrt{1.6}$ | Estimated Weight<br>预估重量 | N/A | Scale<br>比例 | 1:2 | Unit<br>绘图单位 | mm |
|   | ±1.0                  | ±0.2                    | ±0.05                   |                            | ±2°                   | ±0.5°                   |                 |                          |     |             |     |              |    |
| Tolerance Unless Stated Otherwise<br>未注尺寸公差 |                       |                         |                         |                            |                       |                         |                 |                          |     |             |     |              |    |