

HGI Part No. S-9510E-customer	05/07/2021 HENRY JTP APPROVED DOCUMENT	<input checked="" type="checkbox"/> PED 2014/68/EU	<input type="checkbox"/> AS2971.2 / B			<input checked="" type="checkbox"/> UL207	REV. 版本 B	ECN 工程变更通知 ECN-HT21017	Description 变更描述 Delete AS2971.2	Name 变更人 Angel Zhang	Date 变更日期 2021/6/11
			<input type="checkbox"/> CAT I	<input type="checkbox"/> CAT II	Volume Ltrs 0.8	Shell ID mm Ø97	Design Pressure MPa 3.1	Leak Test Pressure MPa 3.1	Proof Test Pressure MPa 3.1	Min Burst Test Pressure MPa 15.5	

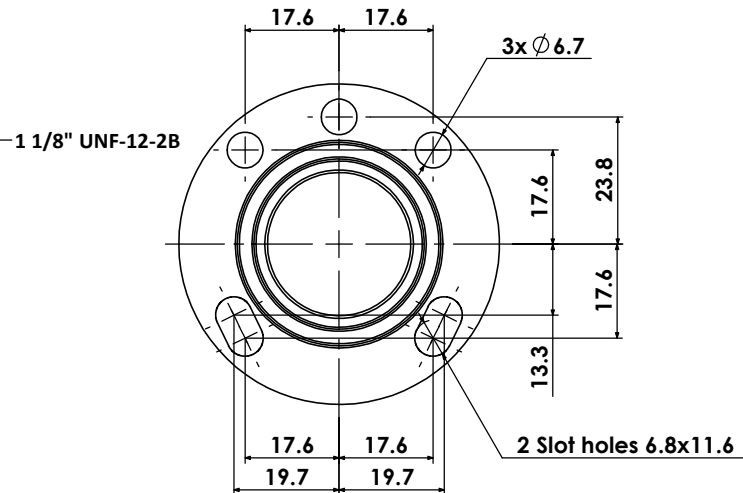

View A-Flange  
Scale 1 : 1

Stamp manufactory code and date code  
冲印工厂代码和制造日期

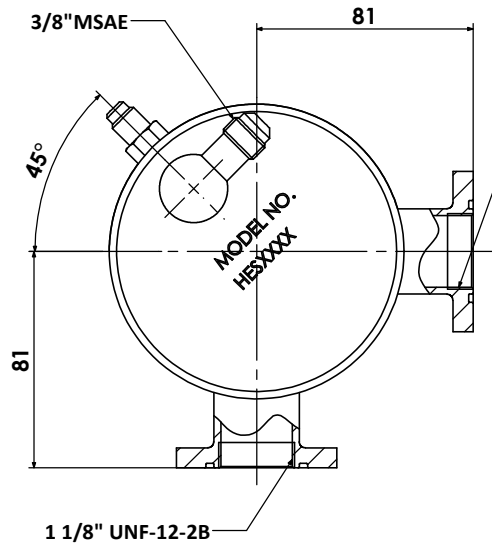
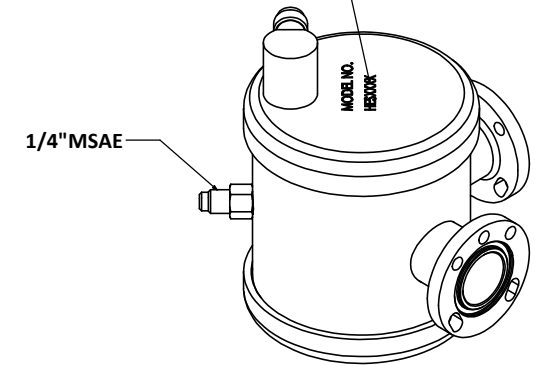

ISO 1:2.5

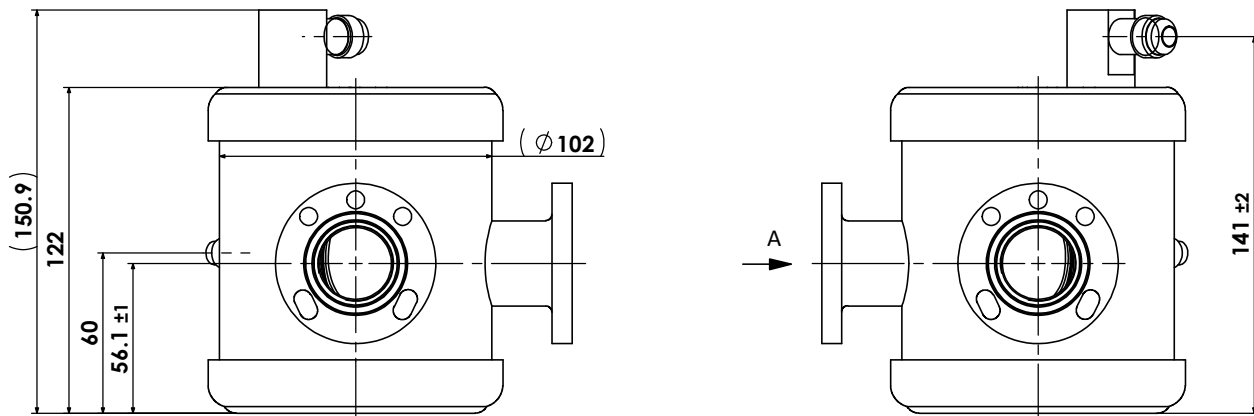

Technical Requirements:  
技术要求

1. Allowable operating temperature 0°C to +130°C;  
工作温度0°C到+130°C;
2. Powder coating: Henry Blue RAL 5013.  
喷涂颜色: 亨利蓝RAL 5013。

Description 产品名称	Mechanical Oil Level Regulator(No Adjustable) 油位调节器(不可调)		
Drawing No. 图纸编号	M050505122	REV 版次	B
Material Master No. 物料编号	050505122	Drawing Size 图幅	A3
Material 材质	N/A	Sheet Number 页码	1/1
Attribute 属性	N/A	Third Angle Projection 第三视角	

Approved_by 批准	Julian Parker	2019/8/29
Checked_by 审核	Leo Wu	2019/8/29
Drawn_by 绘图	Nancy Huang	2019/8/29

Linear Dimensions 线性尺寸 (mm)	0 Decimal Place 整数	1 Decimal Place 1位小数	2 Decimal Place 2位小数	Angular Dimensions 角度尺寸	0 Decimal Place 整数	1 Decimal Place 1位小数	Estimated Weight 预估重量 Scale 比例 Unit 绘图单位	N/A	1:2	mm
	±1.0	±0.2	±0.05		±2°	±0.5°				

Tolerance Unless Stated Otherwise  
未注尺寸公差

