

HGI Part No.		30/03/2022 HENRY JTP APPROVED DOCUMENT		<input checked="" type="checkbox"/> PED 2014/68/EU <input checked="" type="checkbox"/> AS2971.2 <input checked="" type="checkbox"/> UL207		REV. 版本	ECN 工程变更通知	Description 变更描述	Name 变更人	Date 变更日期
SDA-033-customer				<input type="checkbox"/> CAT I <input type="checkbox"/> CAT II <input type="checkbox"/> CAT III		B	ECN-HT22002	Add Stamp "A"	Angel Zhang	2022.3.15
Volume Ltrs	Shell ID mm	Design Pressure MPa	Leak Test Pressure MPa	Proof Test Pressure MPa	Min Burst Test Pressure MPa					
0.1	Ø43.3	4.5	4.5	4.5	22.5					

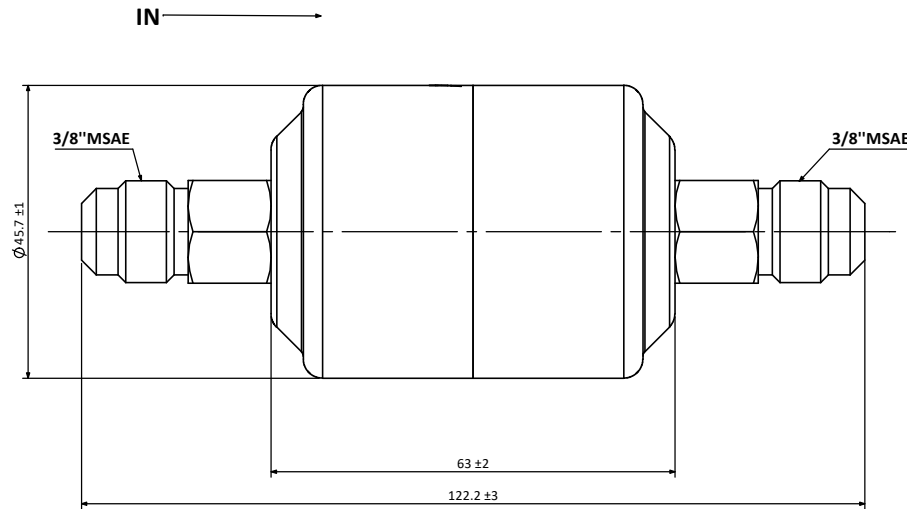

**B**  
HES Stamp "A"  
HES 冲印"A"

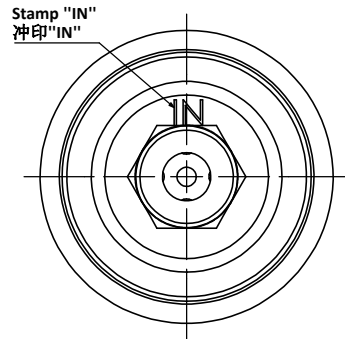
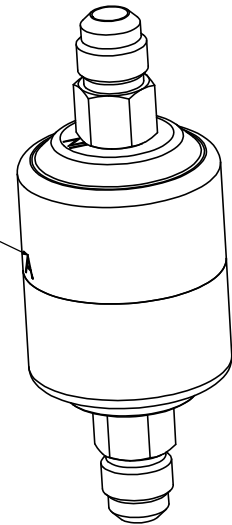

**Technical Requirements:**

**技术要求**

1. Allowable operating temperature -40°C to +100°C;  
工作温度 -40°C到+100°C;
2. Powder coating: Henry Blue, RAL 5013;.  
喷涂颜色: 亨利蓝色, RAL 5013.

Description 产品名称		Liquid Line Filter Drier 3/8" MSAE 干燥过滤器 3/8" MSAE		
Drawing No. 图纸编号	M050505408	REV 版次	B	
Material Master No. 物料编号	050505408	Drawing Size 图幅	A3	
Material 材质	Refer Table	Sheet Number 页码	1/1	
Attribute 属性	3/8" MSAE	Third Angle Projection 第三视角		
Approved_by 批准	Julian Parker	2022/3/15		
Checked_by 审核	Leo Wu	2022/3/15		
Drawn_by 绘图	Angel Zhang	2022/3/15		

Linear Dimensions 线性尺寸 (mm)	0 Decimal Place 整数	1 Decimal Place 1位小数	2 Decimal Place 2位小数	Angular Dimensions 角度尺寸	0 Decimal Place 整数	1 Decimal Place 1位小数	Ra 1.6	Estimated Weight 预估重量	N/A	Approved_by 批准	Julian Parker	2022/3/15
	±1.0	±0.2	±0.05		±2°	±0.5°						
Tolerance Unless Stated Otherwise 未注尺寸公差												