

HGI Part No.	30/03/2022 HENRY JTP APPROVED DOCUMENT
SDA-052S-customer	

<input checked="" type="checkbox"/> PED 2014/68/EU	<input checked="" type="checkbox"/> AS2971.2	<input checked="" type="checkbox"/> UL207			
<input type="checkbox"/> CAT I	<input type="checkbox"/> CAT II	<input type="checkbox"/> CAT III			
Volume Ltrs	Shell ID mm	Design Pressure MPa	Leak Test Pressure MPa	Proof Test Pressure MPa	Min Burst Test Pressure MPa
0.2	N/A	4.5	4.5	4.5	22.5

REV. 版本	ECN 工程变更通知	Description 变更描述	Name 变更人	Date 变更日期
B	ECN-HT22002	Add Stamp "A"	Angel Zhang	2022.3.15

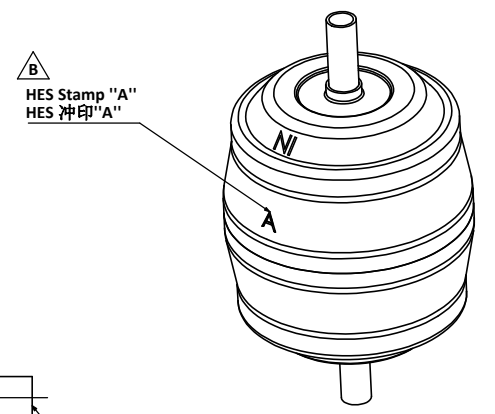
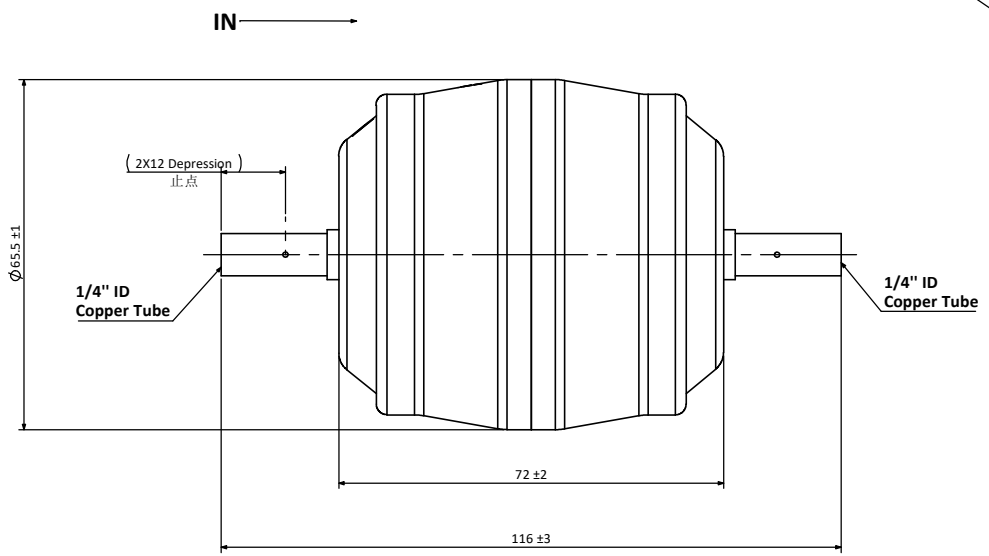
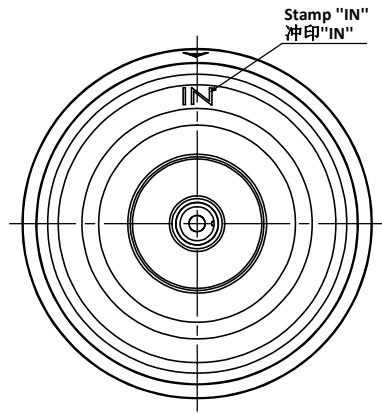

Technical Requirements:
技术要求

1. Allowable operating temperature -40°C to +100°C;
工作温度-40°C到+100°C;
2. Powder coating: Henry Blue, RAL 5013.
喷涂颜色: 亨利蓝色,RAL 5013.

Description 产品名称	Liquid Line Filter Drier 1/4" ID 干燥过滤器 1/4" ID		
Drawing No. 图纸编号	M050505411	REV 版次	B
Material Master No. 物料编号	050505411	Drawing Size 图幅	A3
Material 材质	Refer Table	Sheet Number 页码	1/1
Attribute 属性	1/4"ID	Third Angle Projection 第三视角	
Approved_by 批准	Julian Parker	2022/3/21	
Checked_by 审核	Leo Wu	2022/3/21	
Drawn_by 绘图	Angel Zhang	2022/3/21	

Linear Dimensions 线性尺寸 (mm)	0 Decimal Place	1 Decimal Place	2 Decimal Place	Angular Dimensions 角度尺寸	0 Decimal Place	1 Decimal Place	Estimated Weight 预估重量	N/A
	整数	1位小数	2位小数		整数	1位小数		
	±1.0	±0.2	±0.05		±2°	±0.5°		mm
Tolerance Unless Stated Otherwise 未注尺寸公差								