

|                   |             |  |                        |  |                             |  |  |   |  |         |             |                  |             |           |
|-------------------|-------------|--|------------------------|--|-----------------------------|--|--|---|--|---------|-------------|------------------|-------------|-----------|
| HGI Part No.      |             | 31/03/2022 HENRY<br>JTP<br>APPROVED DOCUMENT |                        | <input checked="" type="checkbox"/> PED 2014/68/EU |                             | <input checked="" type="checkbox"/> AS2971.2 |  | <input checked="" type="checkbox"/> UL207 |  | REV. 版本 | ECN 工程变更通知  | Description 变更描述 | Name 变更人    | Date 变更日期 |
| SDA-0835-customer |             |  |                        | <input type="checkbox"/> CAT I                     |                             | <input type="checkbox"/> CAT II              |  | <input type="checkbox"/> CAT III          |  | B       | ECN-HT22002 | Add Stamp "A"    | Angel Zhang | 2022.3.16 |
| Volume Ltrs       | Shell ID mm | Design Pressure MPa                          | Leak Test Pressure MPa | Proof Test Pressure MPa                            | Min Burst Test Pressure MPa |  |  |   |  |         |             |                  |             |           |
| 0.3               | N/A         | 4.5  | 4.5                    | 4.5  | 22.5                        |  |  |   |  |         |             |                  |             |           |

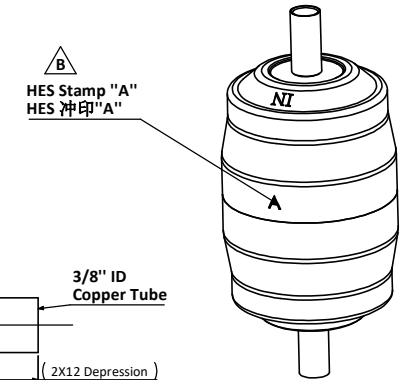
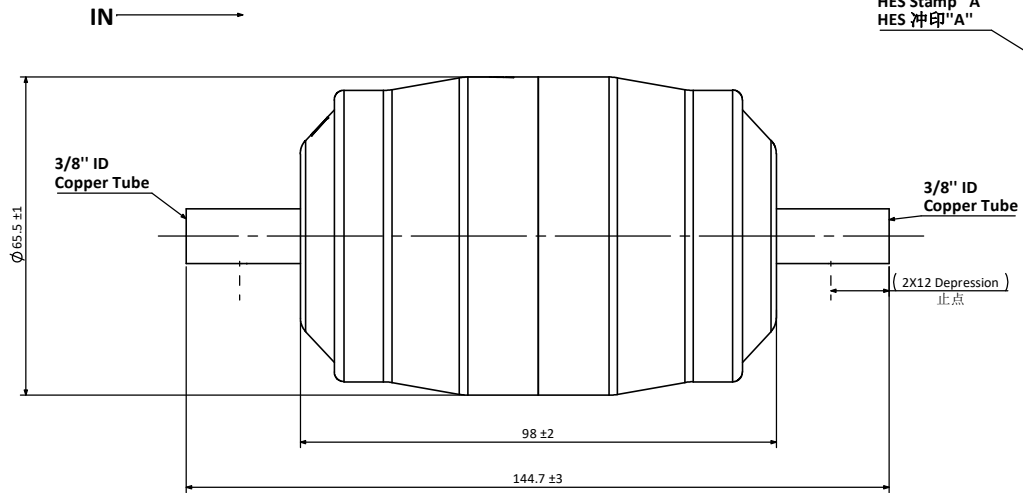
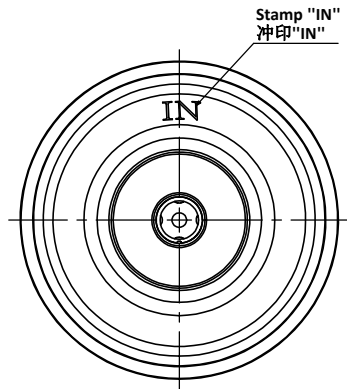

**Technical Requirements:**

**技术要求**

1. Allowable operating temperature -40°C to +100°C;  
工作温度-40°C到+100°C;
2. Powder coating: Henry Blue, RAL 5013;  
喷涂颜色: 亨利蓝色, RAL 5013。

|                          |               |   |     |  |
|--------------------------|---------------|---|-----|--|
| Description 产品名称         |               | Liquid Line Filter Drier 3/8" ID<br>干燥过滤器 3/8" ID |     |  |
| Drawing No. 图纸编号         | M050505417    | REV 版次  | B   |  |
| Material Master No. 物料编号 | 050505417     | Drawing Size 图幅                                   | A3  |  |
| Material 材质              | Refer Table   | Sheet Number 页码                                   | 1/1 |  |
| Attribute 属性             | 3/8"ID        | Third Angle Projection 第三视角                       |     |  |
| Approved_by 批准           | Julian Parker | 2022/3/18   |     |  |
| Checked_by 审核            | Leo Wu        | 2022/3/18   |     |  |
| Drawn_by 绘图              | Angel Zhang   | 2022/3/18   |     |  |

|   |                       |                         |                         |                            |                       |                         |            |   |     |     |    |
|---|-----------------------|-------------------------|-------------------------|----------------------------|-----------------------|-------------------------|------------|---|-----|-----|----|
| Linear Dimensions<br>线性尺寸 (mm)              | 0 Decimal Place<br>整数 | 1 Decimal Place<br>1位小数 | 2 Decimal Place<br>2位小数 | Angular Dimensions<br>角度尺寸 | 0 Decimal Place<br>整数 | 1 Decimal Place<br>1位小数 | Ra 1.6<br> | Estimated Weight<br>预估重量<br>Scale<br>比例<br>Unit<br>绘图单位 | N/A | 1:2 | mm |
|   | ±1.0                  | ±0.2                    | ±0.05                   |                            | ±2°                   | ±0.5°                   |            |   |     |     |    |
| Tolerance Unless Stated Otherwise<br>未注尺寸公差 |                       |                         |                         |                            |                       |                         |            |   |     |     |    |