

HGI Part No.		31/03/2022 HENRY JTP <i>Henry</i> APPROVED DOCUMENT		<input checked="" type="checkbox"/> PED 2014/68/EU <input checked="" type="checkbox"/> AS2971.2 <input checked="" type="checkbox"/> UL207		REV. 版本	ECN 工程变更通知	Description 变更描述	Name 变更人	Date 变更日期
SDA-163-customer				<input type="checkbox"/> CAT I <input type="checkbox"/> CAT II <input type="checkbox"/> CAT III		B	ECN-HT22002	Add Stamp "A"	Angel Zhang	2022.3.16
Volume Ltrs	Shell ID mm	Design Pressure MPa	Leak Test Pressure MPa	Proof Test Pressure MPa	Min Burst Test Pressure MPa					
0.5	N/A	4.5	4.5	4.5	22.5					

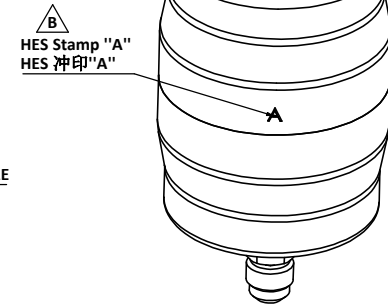
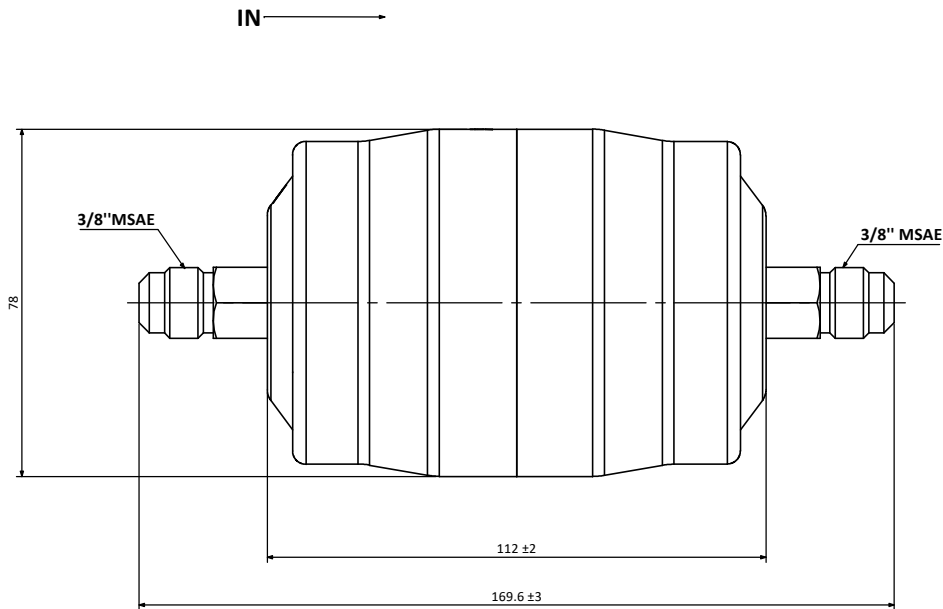
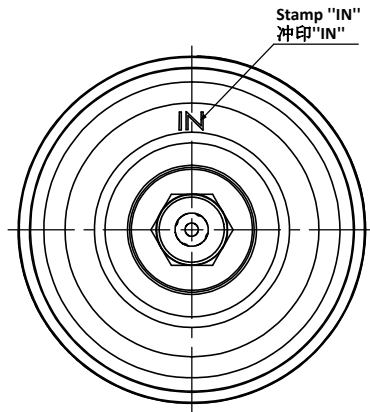

Technical Requirements:
技术要求

1. Allowable operating temperature -40°C to +100°C;
工作温度-40°C到+100°C;
2. Powder coating: Henry Blue, RAL 5013;.
喷涂颜色: 亨利蓝色,RAL 5013.

Description 产品名称	Liquid Line Filter Drier 3/8" MSAE 干燥过滤器 3/8" MSAE		
Drawing No. 图纸编号	M050505422	REV 版次	B
Material Master No. 物料编号	050505422	Drawing Size 图幅	A3
Material 材质	Refer Table	Sheet Number 页码	1/1
Attribute 属性	3/8" MSAE x3/8" MSAE	Third Angle Projection 第三视角	
Approved_by 批准	Julian Parker	2022/3/28	
Checked_by 审核	Leo Wu	2022/3/28	
Drawn_by 绘图	Angel Zhang	2022/3/28	

Linear Dimensions 线性尺寸 (mm)	0 Decimal Place 整数	1 Decimal Place 1位小数	2 Decimal Place 2位小数	Angular Dimensions 角度尺寸	0 Decimal Place 整数	1 Decimal Place 1位小数	Ra $\sqrt{1.6}$	Estimated Weight 预估重量 Scale 比例 Unit 绘图单位	N/A	1:2	mm
	±1.0	±0.2	±0.05		±2°	±0.5°					
Tolerance Unless Stated Otherwise 未注尺寸公差											