

HGI Part No. SDA-304S-customer	05/04/2022 HENRY JTP APPROVED DOCUMENT	<input checked="" type="checkbox"/> PED 2014/68/EU	<input checked="" type="checkbox"/> AS2971.2	<input checked="" type="checkbox"/> UL207	REV. 版本 B	ECN 工程变更通知 ECN-HT22002	Description 变更描述 Add Stamp "A"	Name 变更人 Angel Zhang	Date 变更日期 2022.3.16
		<input type="checkbox"/> CAT I	<input type="checkbox"/> CAT II	<input type="checkbox"/> CAT III	Volume Ltrs 0.9	Shell ID mm N/A	Design Pressure MPa 4.5	Leak Test Pressure MPa 4.5	Proof Test Pressure MPa 4.5

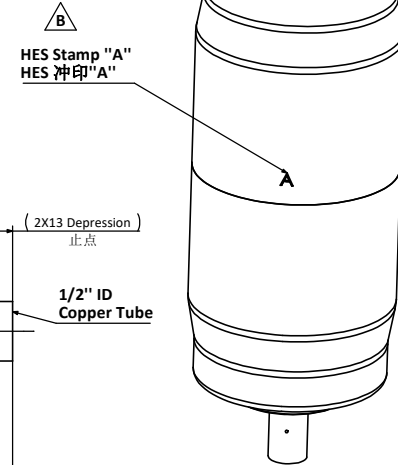
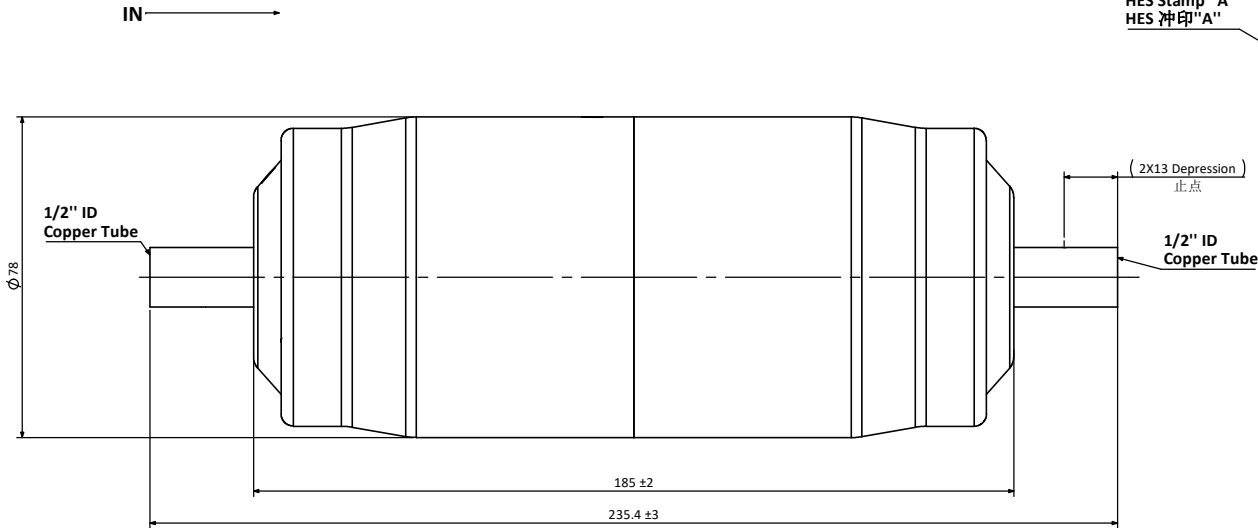
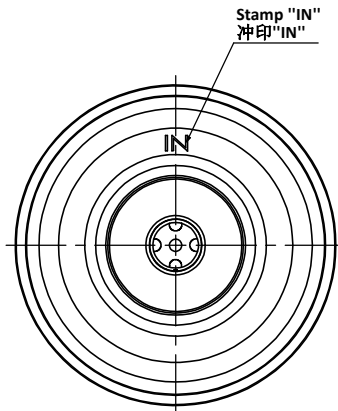

Technical Requirements:
技术要求

1. Allowable operating temperature -40°C to +100°C;
工作温度-40°C到+100°C;
2. Powder coating: Henry Blue, RAL 5013;
喷涂颜色: 亨利蓝色, RAL 5013.

Description 产品名称	Liquid Line Filter Drier 1/2" ID 干燥过滤器 1/2" ID		
Drawing No. 图纸编号	M050505432	REV 版次	B
Material Master No. 物料编号	050505432	Drawing Size 图幅	A3
Material 材质	Refer Table	Sheet Number 页码	1/1
Attribute 属性	1/2" ID	Third Angle Projection 第三视角	
Approved_by 批准	Julian Parker	2022/3/16	
Checked_by 审核	Leo Wu	2022/3/16	
Drawn_by 绘图	Angel Zhang	2022/3/16	

Linear Dimensions 线性尺寸 (mm)	0 Decimal Place 整数	1 Decimal Place 1位小数	2 Decimal Place 2位小数	Angular Dimensions 角度尺寸	0 Decimal Place 整数	1 Decimal Place 1位小数	Ra 1.6	Estimated Weight 预估重量	Scale 比例	Unit 绘图单位
	±1.0	±0.2	±0.05		±2°	±0.5°				
Tolerance Unless Stated Otherwise 未注尺寸公差										