

HGI Part No.
SRC-19221-customer

15/12/2023 HENRY
JTP
APPROVED DOCUMENT

<input checked="" type="checkbox"/> PED 2014/68/EU	<input checked="" type="checkbox"/> AS2971.2	<input checked="" type="checkbox"/> UL207			
<input type="checkbox"/> CAT I	<input checked="" type="checkbox"/> CAT II				
Volume Ltrs	Shell ID mm	Design Pressure MPa	Leak Test Pressure MPa	Proof Test Pressure MPa	Min Burst Test Pressure MPa
5.8	φ108	4.2	4.2	6	21

REV. 版本	ECN 工程变更通知	Description 变更描述	Name 变更人	Date 变更日期

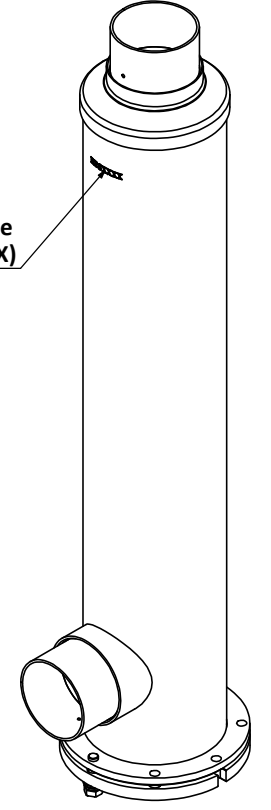
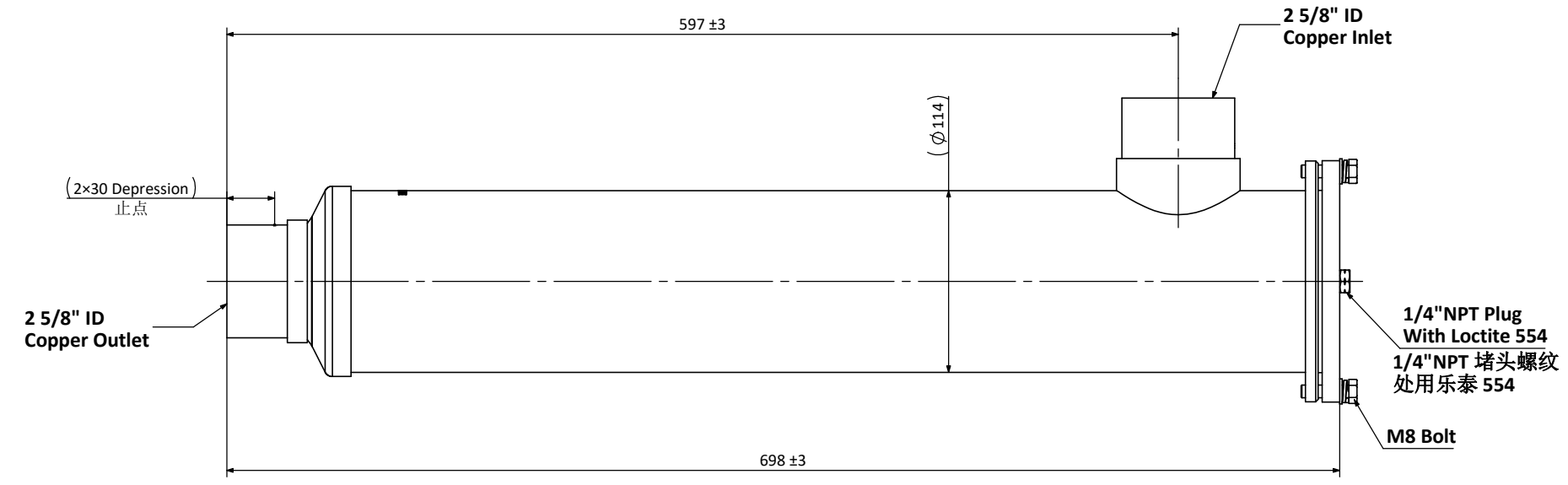
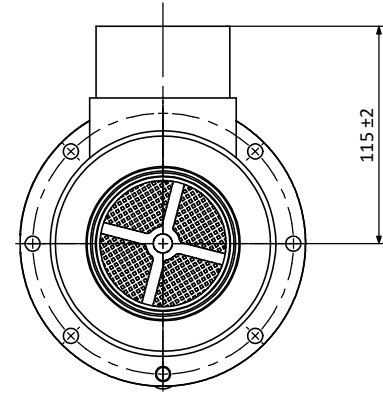

Stamp Manufacturing Code and Date Code (HESXXXX)
冲印生产厂代码和制造日期(HESXXXX)

1/4" NPT Plug With Loctite 554
1/4" NPT 堵头螺纹处用乐泰 554

Technical Requirements:

- 技术要求:
- Allowable operating temperature -40°C to+70°C;
工作温度: -40°C to+70°C;
 - Powder coating: Henry Blue, RAL5013;
喷涂颜色: 亨利蓝色, RAL5013;
 - Bolt pack must be packed with unit in carton.
螺栓随箱包装发货。

Description 产品名称	Replaceable Core Filter Drier Shell 2-5/8" ID 可换滤芯干燥过滤筒 2-5/8" ID		
Drawing No. 图纸编号	M050505715	REV 版次	A
Material Master No. 物料编号	050505715	Drawing Size 图幅	A3
Material 材质	N/A	Sheet Number 页码	1/1
Attribute 属性	2-5/8" ID	Third Angle Projection 第三视角	

Linear Dimensions 线性尺寸 (mm)	0 Decimal Place 整数	1 Decimal Place 1位小数	2 Decimal Place 2位小数	Angular Dimensions 角度尺寸	0 Decimal Place 整数	1 Decimal Place 1位小数	Estimated Weight 预估重量	N/A	Approved_by 批准	Julian Parker	2023/12/11	
	±1.0	±0.2	±0.05		±2°	±0.5°	Scale 比例	1:10	Checked_by 审核	Leo Wu	2023/12/11	
Tolerance Unless Stated Otherwise 未注尺寸公差								Unit 绘图单位	mm	Drawn_by 绘图	Qiu Leixin	2023/12/11

