

HGI Part No. SRC-19221M-customer	 15/12/2023 JTP APPROVED DOCUMENT	<input checked="" type="checkbox"/> PED 2014/68/EU <input checked="" type="checkbox"/> AS2971.2 <input checked="" type="checkbox"/> UL207				REV. 版本	ECN 工程变更通知	Description 变更描述	Name 变更人	Date 变更日期
		<input type="checkbox"/> CAT I <input checked="" type="checkbox"/> CAT II	Volume Ltrs	Shell ID mm	Design Pressure MPa	Leak Test Pressure MPa	Proof Test Pressure MPa	Min Burst Test Pressure MPa		
		5.8	φ108	4.2	4.2	6	21			

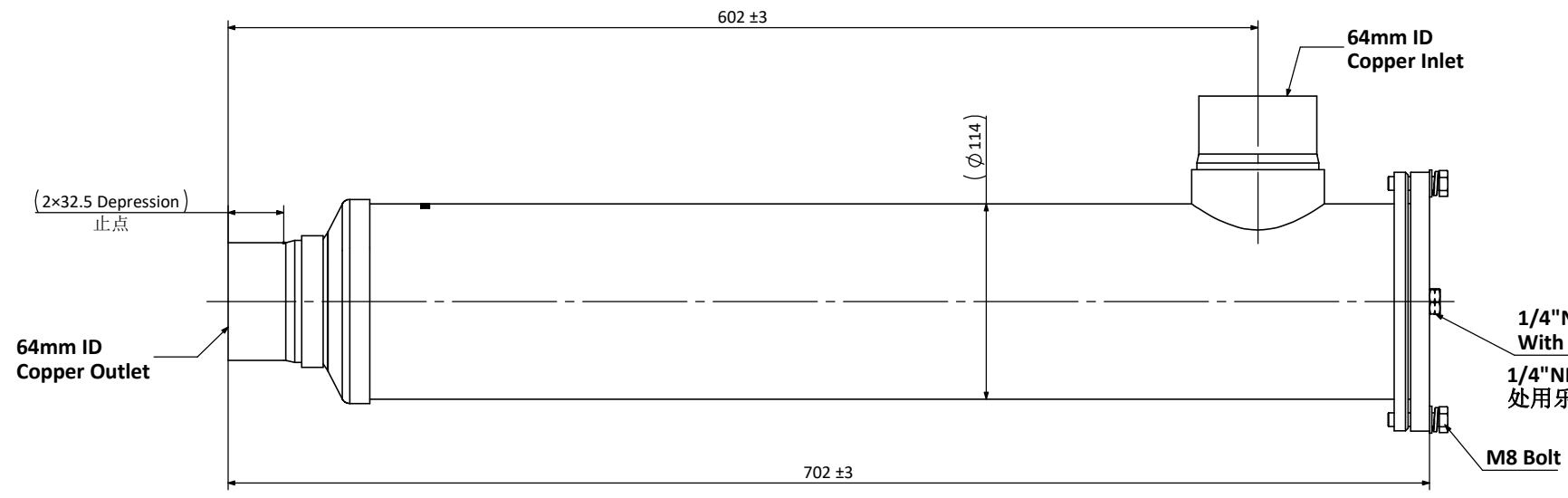

Stamp Manufactory Code and Date Code (HESXXXX)
 冲印生产厂代码和制造日期(HESXXXX)

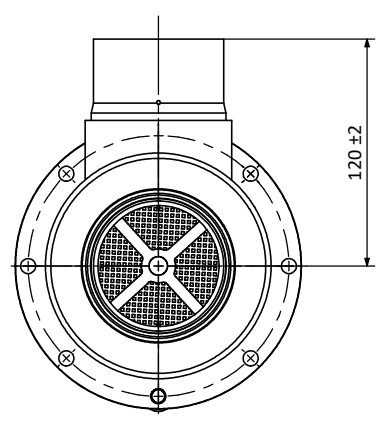
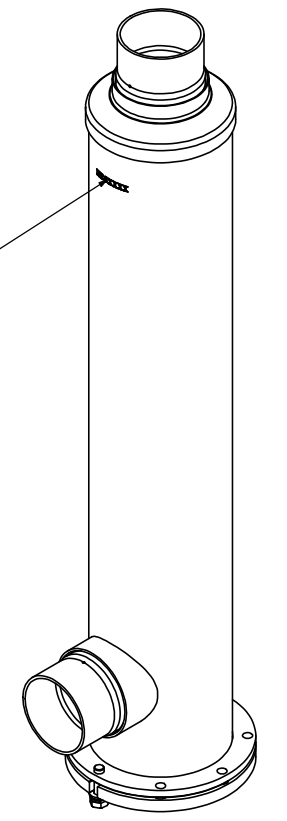

1/4" NPT Plug With Loctite 554
 1/4" NPT 堵头螺纹处用乐泰 554
 M8 Bolt

Technical Requirements:

技术要求:

- Allowable operating temperature -40°C to +70°C;
工作温度: -40°C to +70°C;
- Powder coating: Henry Blue, RAL5013;
喷涂颜色: 亨利蓝色, RAL5013;
- Bolt pack must be packed with unit in carton.
螺栓随箱包装发货。

Description 产品名称	Replaceable Core Filter Drier Shell 64mm ID 可换滤芯干燥过滤器 64mm ID		
Drawing No. 图纸编号	M050505716	REV 版次	A
Material Master No. 物料编号	050505716	Drawing Size 图幅	A3
Material 材质	Refer Table	Sheet Number 页码	1/1
Attribute 属性	64mm ID	Third Angle Projection 第三视角	

Linear Dimensions 线性尺寸 (mm)	0 Decimal Place 整数	1 Decimal Place 1位小数	2 Decimal Place 2位小数	Angular Dimensions 角度尺寸	0 Decimal Place 整数	1 Decimal Place 1位小数	Ra 1.6 	Estimated Weight 预估重量	N/A	Approved_by 批准	Julian Parker	2023/12/11
	±1.0	±0.2	±0.05		±2°	±0.5°		Scale 比例	1:4	Checked_by 审核	Leo Wu	2023/12/11
Tolerance Unless Stated Otherwise 未注尺寸公差								Unit 绘图单位	mm	Drawn_by 绘图	Qiu Leixin	2023/12/11

