

HGI Part No. SRC-4813M-customer	 11/02/2022 HENRY JTP APPROVED DOCUMENT	<input checked="" type="checkbox"/> PED 2014/68/EU <input checked="" type="checkbox"/> AS2971.2 <input checked="" type="checkbox"/> UL207				REV. 版本	ECN 工程变更通知	Description 变更描述	Name 变更人	Date 变更日期
		<input type="checkbox"/> CAT I <input checked="" type="checkbox"/> CAT II	Volume Ltrs	Shell ID mm	Design Pressure MPa	Leak Test Pressure MPa	Proof Test Pressure MPa	Min Burst Test Pressure MPa		
		1.7	φ108	4.2	4.2	6.0	21.0			

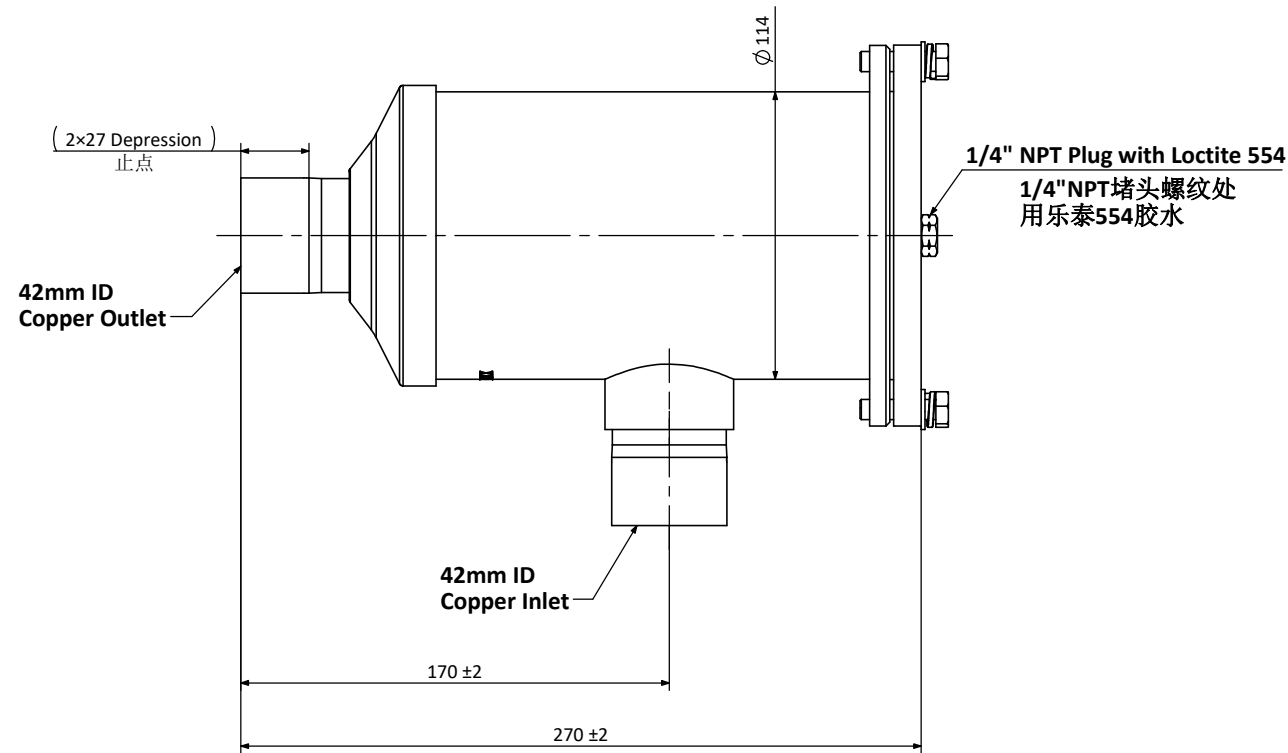

Stamp Manufactory Code and Date Code (HESXXXX)  
 冲印生产厂代码和制造日期(HESXXXX)

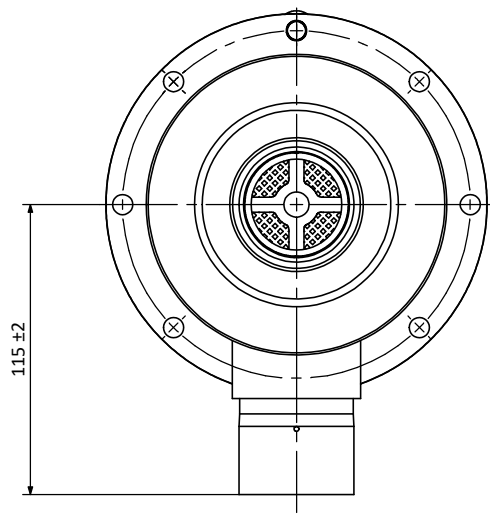
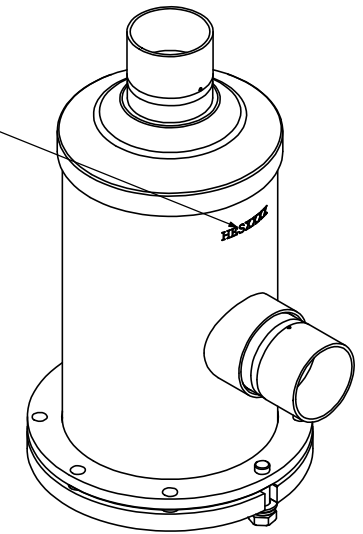

**Technical Requirements:**

技术要求:

- Allowable operating temperature -40°C to+70°C;  
工作温度: -40°C to+70°C;
- Powder coating: Henry Blue, RAL5013;  
喷涂颜色: 亨利蓝色, RAL5013;
- Bolt pack must be packed with unit in carton.  
螺栓包必须随箱包装。

Description 产品名称	Replaceable Core Filter Drier Shell 42mm ID 可换滤芯干燥过滤器 42mm ID		
Drawing No. 图纸编号	M050505508	REV 版次	A
Material Master No. 物料编号	050505508	Drawing Size 图幅	A3
Material 材质	N/A	Sheet Number 页码	1/1
Attribute 属性	42mm ID	Third Angle Projection 第三视角	

Linear Dimensions 线性尺寸 (mm)	0 Decimal Place 整数	1 Decimal Place 1位小数	2 Decimal Place 2位小数	Angular Dimensions 角度尺寸	0 Decimal Place 整数	1 Decimal Place 1位小数	Ra 1.6 	Estimated Weight 预估重量	N/A	Approved_by 批准 Julian Parker 2021/10/21
	±1.0	±0.2	±0.05		±2°	±0.5°		Scale 比例	1:3	
Tolerance Unless Stated Otherwise 未注尺寸公差								Unit 绘图单位	mm	Drawn_by 绘图 Qiu Leixin 2021/10/21

