

HGI Part No. 08/02/2022 HENRY
 JTP APPROVED DOCUMENT
 SRC-9621-customer

<input checked="" type="checkbox"/> PED 2014/68/EU		<input checked="" type="checkbox"/> AS2971.2		<input checked="" type="checkbox"/> UL207	
<input type="checkbox"/> CAT I		<input checked="" type="checkbox"/> CAT II			
Volume Ltrs	Shell ID mm	Design Pressure MPa	Leak Test Pressure MPa	Proof Test Pressure MPa	Min Burst Test Pressure MPa
3	φ108	4.2	4.2	6	21

REV. 版本	ECN 工程变更通知	Description 变更描述	Name 变更人	Date 变更日期

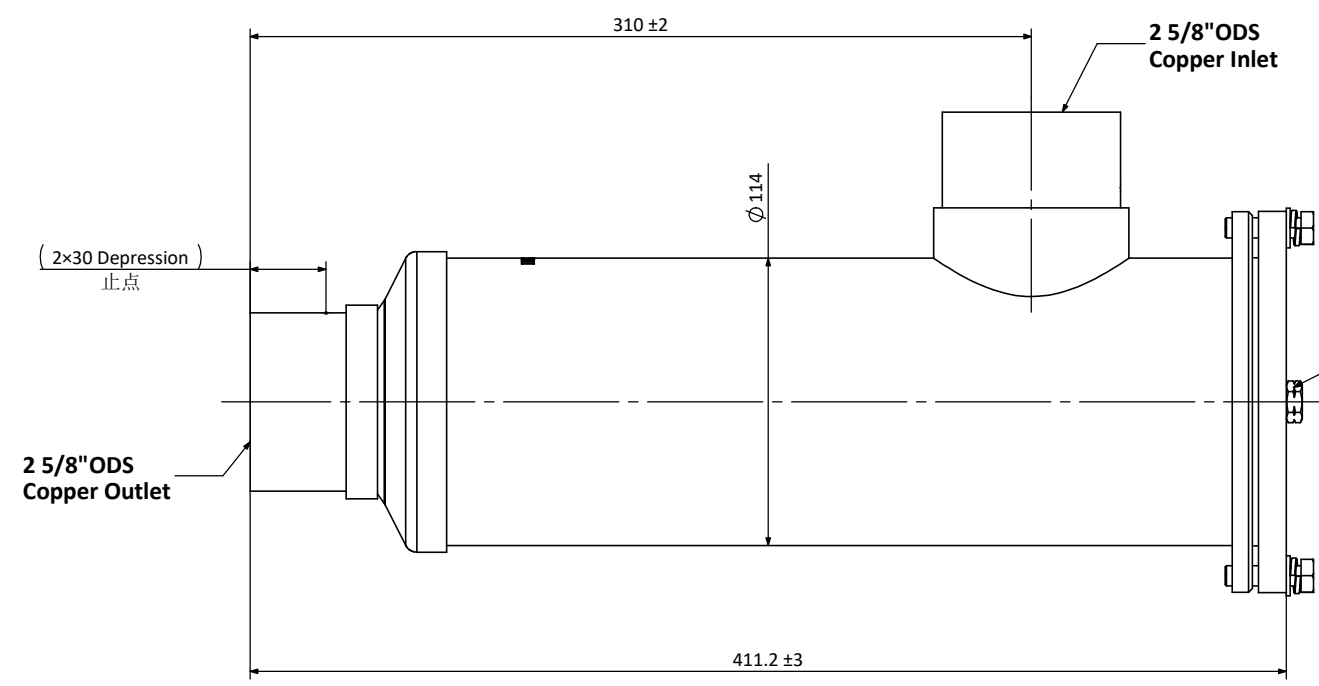
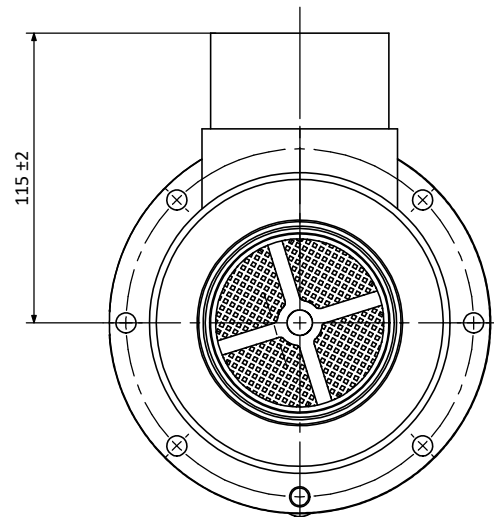

Stamp Manufacture Code and Date Code (HESXXXX)
 冲印生产厂代码和制造日期(HESXXXX)

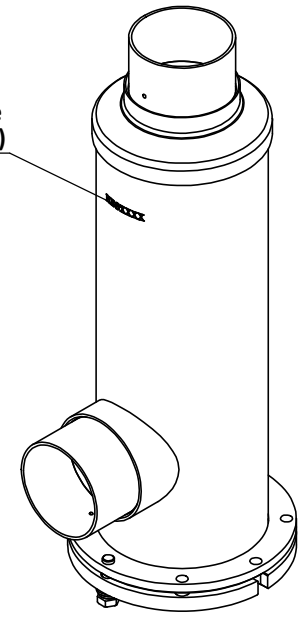

Technical Requirements:

技术要求:

1. Allowable operating temperature -40°C to +70°C;
工作温度: -40°C to +70°C;
2. Powder coating: Henry Blue, RAL5013;
喷涂颜色: 亨利蓝色, RAL5013;
3. Bolt pack must be packed with unit in carton.
螺栓包必须随箱包装。

Description 产品名称	Replaceable Core Filter Drier Shell 可换滤芯干燥过滤筒		
Drawing No. 图纸编号	M050505543	REV 版次	A
Material Master No. 物料编号	050505543	Drawing Size 图幅	A3
Material 材质	2 5/8"	Sheet Number 页码	1/1
Attribute 属性	N/A	Third Angle Projection 第三视角	

Linear Dimensions 线性尺寸 (mm)	0 Decimal Place 整数	1 Decimal Place 1位小数	2 Decimal Place 2位小数	Angular Dimensions 角度尺寸	0 Decimal Place 整数	1 Decimal Place 1位小数	Ra 1.6	Estimated Weight 预估重量	N/A	Approved_by 批准	Julian Parker	2021/8/31
	±1.0	±0.2	±0.05		±2°	±0.5°		Scale 比例	1:5	Checked_by 审核	Leo Wu	2021/8/31
	Tolerance Unless Stated Otherwise 未注尺寸公差							Unit 绘图单位	mm	Drawn_by 绘图	Qiu Leixin	2021/8/31

