

HGI Part No. 1004-4226

08/01/2019 HENRY JTP APPROVED DOCUMENT

REV. 版本	ENC 工程变更通知	Description 变更描述	Name 变更人	Date 变更日期
△ B	ECN-HT19002	Logo location changed to ODF side	Cai Wangwang	2019.1.3

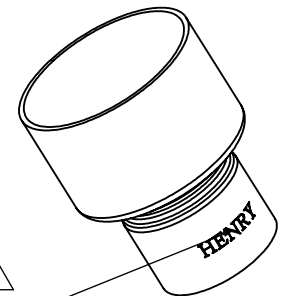
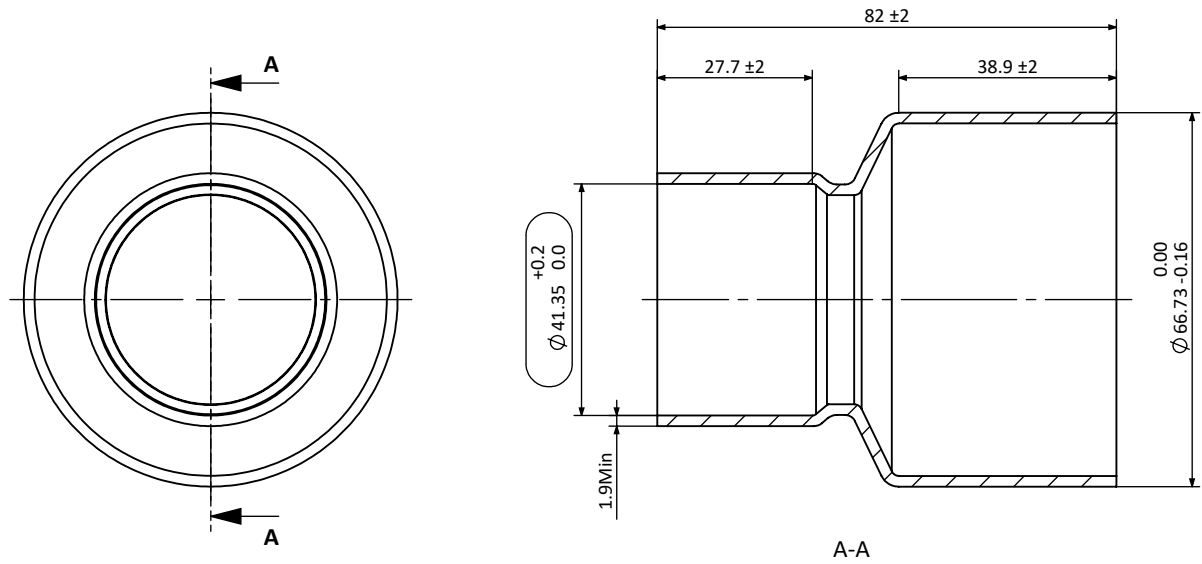

Stamping "HENRY" △ B
 Font :AGaramond LT Bold
 冲印 "HENRY"
 字体 : AGaramond LT Bold

Technical requirements:

技术要求 :

- Copper tube must comply with ASTM B280 or AS 1432-1966 99.90% min Cu and min Ph of 0.015% and 0.040% max;
铜管必须符合ASTM B280 或AS 1432-1966标准,最小含铜量99.90% , 最小Ph 0.015% , 最大Ph0.04%;
- Maximum of 1% ovality acceptable for the connection pockets;
承接口处椭圆度≤1%;
- Parts need to be branded according to logo requirement;
零件需按要求打印商标 ;
- No sharp edges or shoulders. All changes in shape must be with a smooth and suitable radius for maximum strength;
没有飞边和毛刺 , 所有形状改变的地方必须是平滑的并且适用于最大强度;
- Minimum Wall thickness is the minimum wall thickness anywhere within the fitting after forming;
最小壁厚是指成型后任意位置的壁厚。

Description 产品名称	Copper Coupling 2 5/8" OD x 1 5/8" ID 直通 2 5/8"ODx1 5/8"ID		
Drawing No. 图纸编号	M040201085	REV 版次	B
Material Master No. 物料编号	040201085	Drawing Size 图幅	A4
Material 材质	TP2	Sheet Number 页码	1/1
Attribute 属性	2 5/8"ODx1 5/8"ID	Third Angle Projection 第三视角	

Linear Dimensions 线性尺寸	Dimensions inside an oval are critical dimensions 椭圆内尺寸为关键尺寸			Angular Dimensions 角度尺寸	Estimated Weight 预估重量	Scale 比例	Unit 绘图单位
	0 Decimal Place 整数	1 Decimal Place 1位小数	2 Decimal Place 2位小数				
±1.0	±0.2	±0.05	±2°	±0.5°	327 g	1:2	mm

Tolerance Unless Stated Otherwise 未注尺寸公差

Approved_by 批准	Julian Parker	1/3/2019
Checked_by 审核	Leo Wu	1/3/2019
Drawn_by 绘图	Reuben Fan	1/3/2019

