

HGI Part No. 1004-4834		08/01/2019 HENRY JTP APPROVED DOCUMENT		REV. 版本 △B	ENC 工程变更通知 ECN-HT19002	Description 变更描述 Logo location changed to ODF side	Name 变更人 Cai Wangwang	Date 变更日期 2019.1.3
----------------------------------	--	--	--	----------------------	----------------------------------	--	---------------------------------	------------------------------

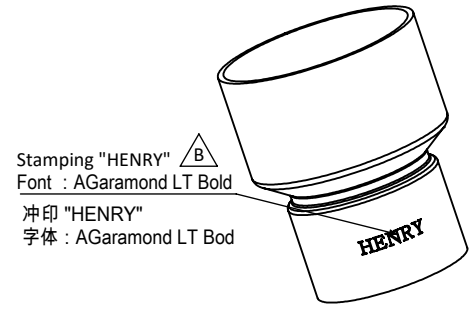
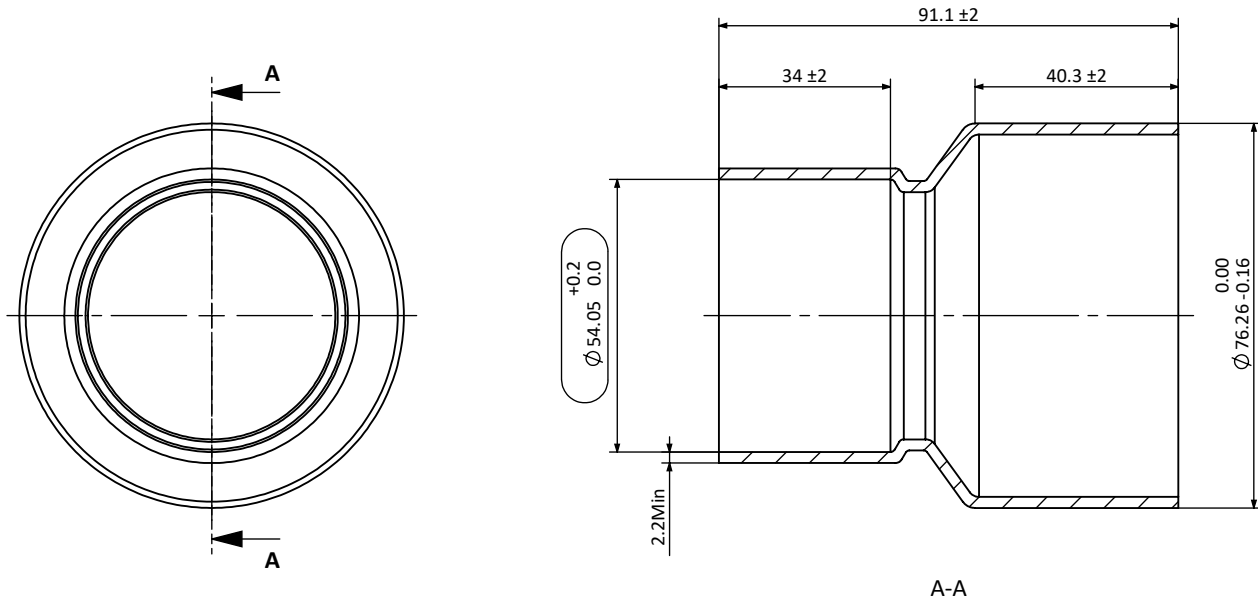

Technical requirements:

技术要求 :

- Copper tube must comply with ASTM B280 or AS 1432-1966 99.90% min Cu and min Ph of 0.015% and 0.040% max;
铜管必须符合ASTM B280 或AS 1432-1966标准,最小含铜量99.90% , 最小Ph 0.015% , 最大Ph0.04% ;
- Maximum of 1% ovality acceptable for the connection pockets;
承接口处椭圆度≤1% ;
- Parts need to be branded according to logo requirement;
零件需按要求打印商标 ;
- No sharp edges or shoulders. All changes in shape must be with a smooth and suitable radius for maximum strength;
没有飞边和毛刺 , 所有形状改变的地方必须是平滑的并且适用于最大强度 ;
- Minimum Wall thickness is the minimum wall thickenss anywhere within the fitting after forming;
最小壁厚是指成型后任意位置的壁厚。

Description 产品名称	Copper Coupling 3" OD x 2 1/8" ID 直通 3"ODx2 1/8"ID		
Drawing No. 图纸编号	M040201091	REV 版次	B
Material Master No. 物料编号	040201091	Drawing Size 图幅	A4
Material 材质	TP2	Sheet Number 页码	1/1
Attribute 属性	3"ODx2 1/8"ID	Third Angle Projection 第三视角	

Linear Dimensions 线性尺寸	0 Decimal Place 整数	1 Decimal Place 1位小数	2 Decimal Place 2位小数	Angular Dimensions 角度尺寸	0 Decimal Place 整数	1 Decimal Place 1位小数	Ra 1.6 	Estimated Weight 预估重量	436.5 g	Approved_by 批准	Julian Parker	1/3/2019
	±1.0	±0.2	±0.05		±2°	±0.5°		Scale 比例	1:2		Checked_by 审核	Leo Wu
Tolerance Unless Stated Otherwise 未注尺寸公差								Unit 绘图单位	mm	Drawn_by 绘图	Reuben Fan	1/3/2019

