



| | |
|--------------|---|
| HGI Part No. | 22/08/2018  HENRY JTP  APPROVED DOCUMENT |
| 1004Z-2210 | |

| REV. 版本 | ENC 工程变更通知 | Description 变更描述 | Name 变更人 | Date 变更日期 |
|---------|------------|------------------|----------|-----------|
| | | | | |
| | | | | |
| | | | | |

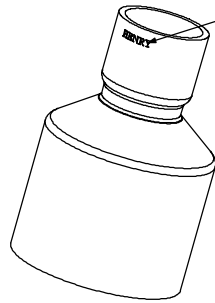
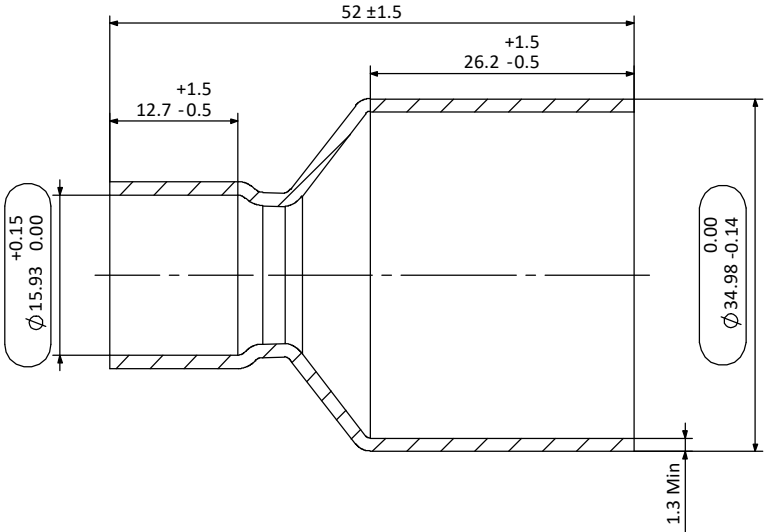
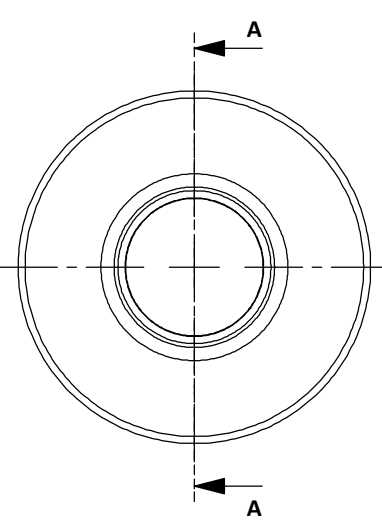

Stamping "HENRY"
Font:AGaramond LT Bold
冲印"HENRY"
字体: AGaramond LT Bold

A-A

Technical requirements:

技术要求:

- Copper tube must comply with ASTM B280 or AS 1432-1966 99.90% min Cu and min Ph of 0.015% and 0.040% max;
铜管必须符合ASTM B280 或AS 1432-1966标准,最小含铜量99.90%, 最小Ph 0.015%, 最大Ph0.04%;
- Maximum of 1% ovality acceptable for the connection pockets;
承接口处椭圆度≤1%;
- Parts need to be branded according to logo requirement;
零件需按要求打印商标;
- No sharp edges or shoulders. All changes in shape must be with a smooth and suitable radius for maximum strength;
没有飞边和毛刺, 所有形状改变的地方必须是平滑的并且适用于最大强度;
- Minimum Wall thickness is the minimum wall thickness anywhere within the fitting after forming;
最小壁厚是指成型后任意位置的壁厚。

| | | | |
|--------------------------|--|-----------------------------|---|
| Description 产品名称 | Bush (CU) 1 3/8 OD x 5/8 ID 铜衬套 1 3/8 OD x 5/8 ID | | |
| Drawing No. 图纸编号 | M040201721 | REV 版次 | A |
| Material Master No. 物料编号 | 040201721 | Drawing Size 图幅 | A4 |
| Material 材质 | TP2 | Sheet Number 页码 | 1/1 |
| Attribute 属性 | 1 3/8 OD x 5/8 ID | Third Angle Projection 第三视角 |  |

| | | | | | | | | | |
|--|--------------------|----------------------|----------------------|-------------------------|--------------------|----------------------|--------|-----------------------|------|
| Linear Dimensions 线性尺寸 | 0 Decimal Place 整数 | 1 Decimal Place 1位小数 | 2 Decimal Place 2位小数 | Angular Dimensions 角度尺寸 | 0 Decimal Place 整数 | 1 Decimal Place 1位小数 | Ra 1.6 | Estimated Weight 预估重量 | 65 g |
| | ±1.0 | ±0.2 | ±0.05 | | ±2° | ±0.5° | | Scale 比例 | 1:1 |
| Tolerance Unless Stated Otherwise 未注尺寸公差 | | | | | | | | Unit 绘图单位 | mm |

| | | |
|----------------|---------------|----------|
| Approved_by 批准 | Julian Parker | 2018/8/9 |
| Checked_by 审核 | Leo Wu | 2018/8/9 |
| Drawn_by 绘图 | Reuben Fan | 2018/8/9 |



A

B

C

D