

A		B			C			D	
HGI Part No.	22/08/2018 HENRY JTP <i>sothe</i> APPROVED DOCUMENT	REV. 版本	ENC 工程变更通知	Description 变更描述	Name 变更人	Date 变更日期			
1004Z-2214-410A									

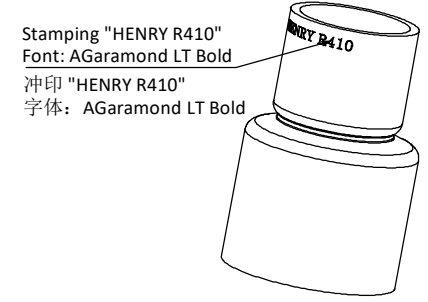
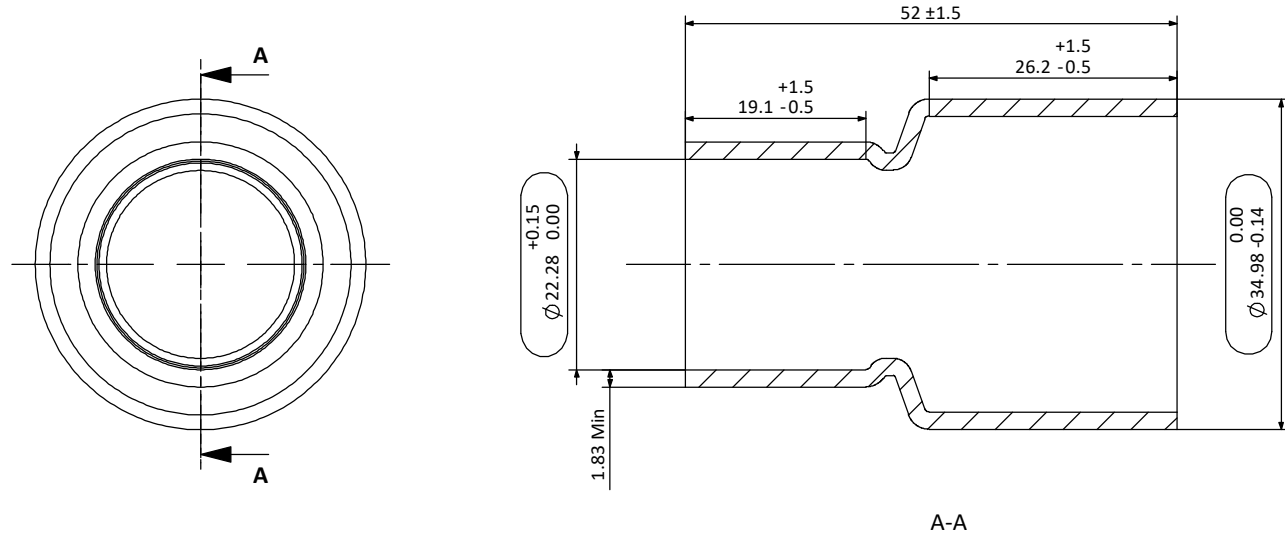

Technical requirements:

- 技术要求:
- Copper tube must comply with ASTM B280 or AS 1432-1966 99.90% min Cu and min Ph of 0.015% and 0.040% max;
铜管必须符合ASTM B280 或AS 1432-1966标准,最小含铜量99.90%, 最小Ph 0.015%, 最大Ph0.04%;
 - Maximum of 1% ovality acceptable for the connection pockets;
承接口处椭圆度≤1%;
 - Parts need to be branded according to logo requirement;
零件需按要求打印商标;
 - No sharp edges or shoulders. All changes in shape must be with a smooth and suitable radius for maximum strength;
没有飞边和毛刺, 所有形状改变的地方必须是平滑的并且适用于最大强度;
 - Minimum Wall thickness is the minimum wall thickness anywhere within the fitting after forming;
最小壁厚是指成型后任意位置的壁厚。

Description 产品名称	Bush (CU) 1 3/8 OD x 7/8 ID R410A 铜衬套 1 3/8 OD x 7/8 ID R410A		
Drawing No. 图纸编号	M040201724	REV 版次	A
Material Master No. 物料编号	040201724	Drawing Size 图幅	A4
Material 材质	TP2	Sheet Number 页码	1/1
Attribute 属性	1 3/8 OD x 7/8 ID	Third Angle Projection 第三视角	

Linear Dimensions 线性尺寸	0 Decimal Place 整数	1 Decimal Place 1位小数	2 Decimal Place 2位小数	Angular Dimensions 角度尺寸	0 Decimal Place 整数	1 Decimal Place 1位小数	Ra 1.6	Estimated Weight 预估重量	97.5 g
	±1.0	±0.2	±0.05		±2°	±0.5°			
Tolerance Unless Stated Otherwise 未注尺寸公差								Unit 绘图单位	mm

Approved_by 批准	Julian Parker	2018/8/16
Checked_by 审核	Leo Wu	2018/8/16
Drawn_by 绘图	Reuben Fan	2018/8/16

