



HGI Part No.	27/08/2020  HENRY JTP  APPROVED DOCUMENT
1062-1636	

REV. 版本	ECN 工程变更通知	Description 变更描述	Name 变更人	Date 变更日期

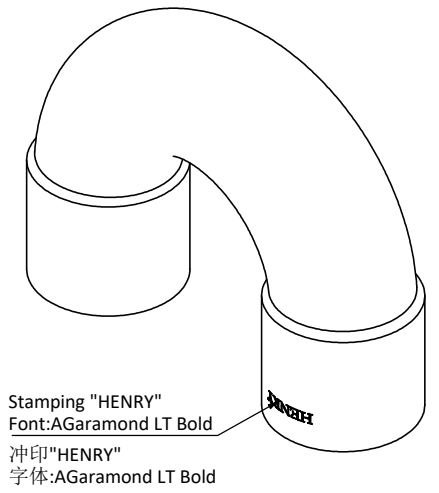
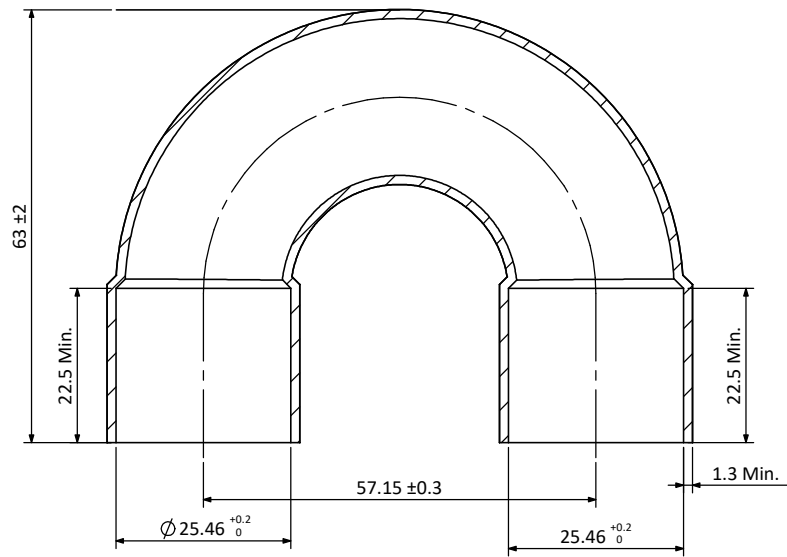
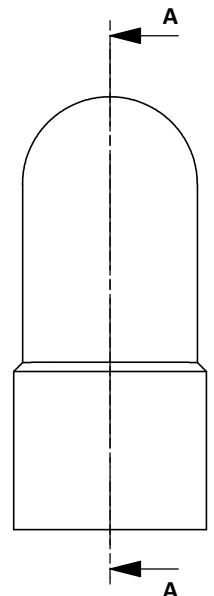

Technical requirements:

技术要求:

- Copper tube must comply with ASTM B280 or AS 1432-1966 99.90% min Cu and min Ph of 0.015% and 0.040% max;
铜管必须符合ASTM B280 或AS 1432-1966标准,最小含铜量99.90%, 最小Ph 0.015%, 最大Ph0.04%;
- Maximum of 1% ovality acceptable for the connection pockets;
承接口处椭圆度≤1%;
- Parts need to be branded according to logo requirement;
零件需按要求打印商标;
- No sharp edges or shoulders. All changes in shape must be with a smooth and suitable radius for maximum strength;
没有飞边和毛刺, 所有形状改变的地方必须是平滑的并且适用于最大强度;
- Minimum Wall thickness is the minimum wall thickness anywhere within the fitting after forming;
最小壁厚是指成型后任意位置的壁厚;
- Material certificates must be supplied each batch;
每批产品需提供材质分析报告;

Section A-A

Description 产品名称		Return Bend 1" ID × 2 1/4" CTR U型弯头 1" ID × 2 1/4" CTR	
Drawing No. 图纸编号	M040201438	REV 版次	A
Material Master No. 物料编号	040201438	Drawing Size 图幅	A4
Material 材质	TP2	Sheet Number 页码	1/1
Attribute 属性	1" ID × 2 1/4" CTR	Third Angle Projection 第三视角	

Dimensions inside an oval are critical dimensions
椭圆内尺寸为关键尺寸

Linear Dimensions 线性尺寸	0 Decimal Place 整数	1 Decimal Place 1位小数	2 Decimal Place 2位小数	Angular Dimensions 角度尺寸	0 Decimal Place 整数	1 Decimal Place 1位小数	Ra 1.6	Estimated Weight 预估重量	116.84g
	±1.0	±0.2	±0.05		±2°	±0.5°		Scale 比例	1:1
Tolerance Unless Stated Otherwise 未注尺寸公差								Unit 绘图单位	mm

Approved_by 批准	Julian Parker	2020/8/24
Checked_by 审核	Leo Wu	2020/8/24
Drawn_by 绘图	Angel Zhang	2020/8/19



A

B

C

D