

HGI Part No.	<div style="border: 1px solid black; padding: 5px;"> 21/08/2020 HENRY JTP <i>with</i> APPROVED DOCUMENT </div>
1110-08	

REV. 版本	ECN 工程变更通知	Description 变更描述	Name 变更人	Date 变更日期
D	ECN-HT18009	T change to T±0.05 尺寸T公差改为 T±0.05	Reuben Fan	2018.3.12
E	ECN-HT20060	Change material from TP2 to T2, change tolerance from 8±0.05 to 8(+0.05/-0.1)	Qiu Leixin	2020.08.18

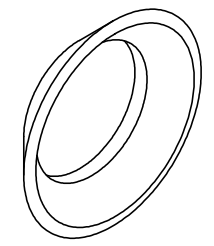
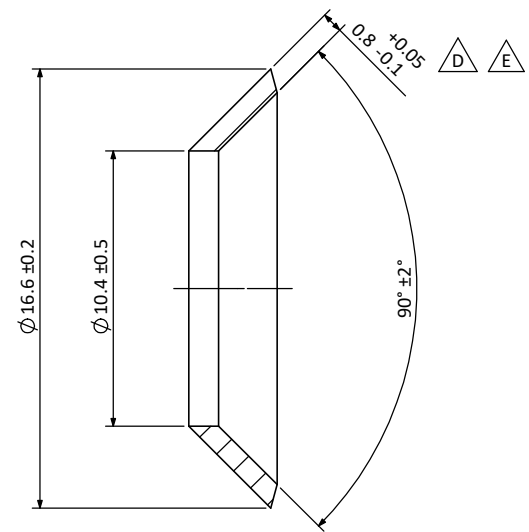
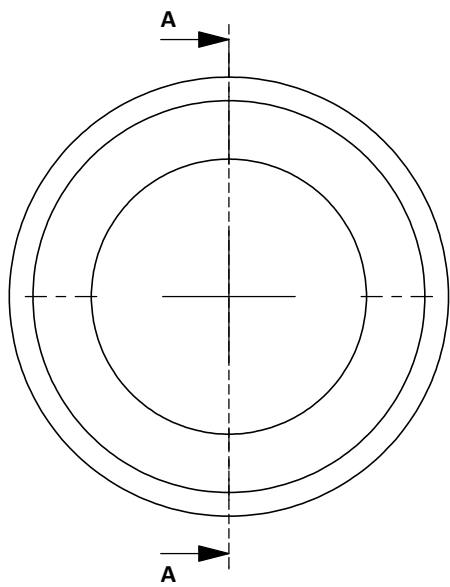

Section A-A

Technical Requirement:
技术要求:

- All edges free of burr or flash;
不能有毛刺和飞边;
- Surface should be clean and no rust(except oil stain);
表面应干净无生锈(油渍除外)
- Material certificates must be supplied each batch;
每批产品需提供材质分析报告;
- Unspecified geometric tolerance according to ISO 2768-K.
未注形位公差参照ISO-2768-K执行。

Description 产品名称		Flare Washer 1/2" 锥垫片 1/2"	
Drawing No. 图纸编号	M040201474	REV 版次	E
Material Master No. 物料编号	040201474	Drawing Size 图幅	A4
Material 材质	T2	Sheet Number 页码	1/1
Attribute 属性	1/2"	Third Angle Projection 第三视角	

Dimensions inside an oval are critical dimensions
椭圆内尺寸为关键尺寸

Linear Dimensions 线性尺寸	0 Decimal Place 整数	1 Decimal Place 1位小数	2 Decimal Place 2位小数	Angular Dimensions 角度尺寸	0 Decimal Place 整数	1 Decimal Place 1位小数	Ra 1.6	Estimated Weight 预估重量	1.10g
	±1.0	±0.2	±0.05		±2°	±0.5°		Scale 比例	2:1
Tolerance Unless Stated Otherwise 未注尺寸公差								Unit 绘图单位	mm

Approved_by 批准	Julian Parker	2020/07/24
Checked_by 审核	Leo Wu	2020/07/24
Drawn_by 绘图	Angel Zhang	2020/07/24



A

B

C

D