

HGI Part No.	21/08/2020  HENRY JTP APPROVED DOCUMENT
1110-16	

REV. 版本	ECN 工程变更通知	Description 变更描述	Name 变更人	Date 变更日期
B	ECN-HT20060	Change material from TP2 to T2, Add the tolerance $\phi 21.4 \pm 0.5$ , $0.8 (+0.05/-0.1)$ replace $0.9$ , $90^\circ \pm 2^\circ$ replace $45^\circ \pm 2^\circ$	Qiu Leixin	2020/08/18

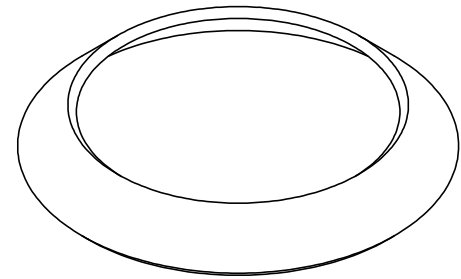
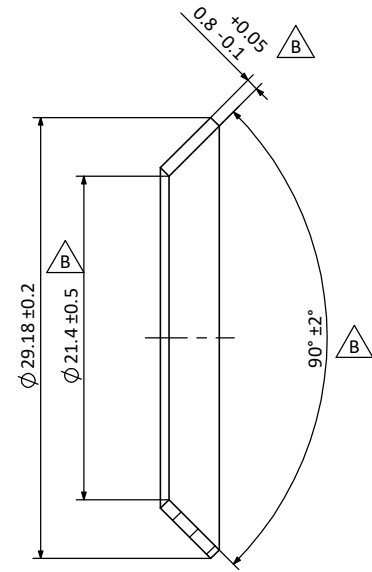
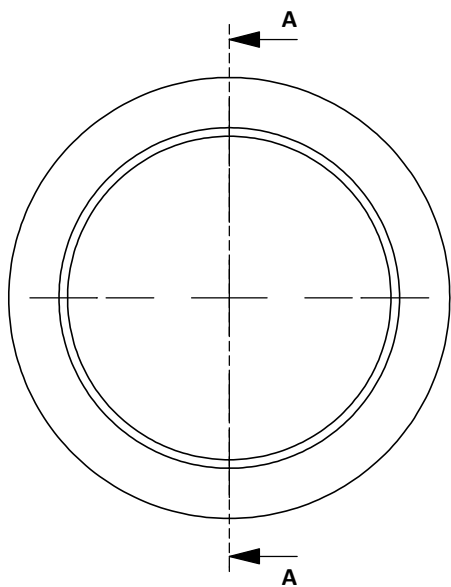

Section A-A

Technical Requirement:

技术要求:

- All edges free of burr or flash;  
不能有毛刺和飞边;
- Surface should be clean and no rust(except oil stain);  
表面应干净无生锈(油渍除外)
- Material certificates must be supplied each batch;  
每批产品需提供材质分析报告;
- Unspecified geometric tolerance according to ISO 2768-K.  
未注形位公差参照ISO-2768-K执行。

Description 产品名称	Flare Washer 1" 锥垫片 1"		
Drawing No. 图纸编号	M040201477	REV 版次	B
Material Master No. 物料编号	040201477	Drawing Size 图幅	A4
Material 材质	T2	Sheet Number 页码	1/1
Attribute 属性	N/A	Third Angle Projection 第三视角	

Dimensions inside an oval are critical dimensions  
椭圆内尺寸为关键尺寸

Linear Dimensions 线性尺寸	0 Decimal Place 整数	1 Decimal Place 1位小数	2 Decimal Place 2位小数	Angular Dimensions 角度尺寸	0 Decimal Place 整数	1 Decimal Place 1位小数	Ra 1.6	Estimated Weight 预估重量	2.66g
	$\pm 1.0$	$\pm 0.2$	$\pm 0.05$		$\pm 2^\circ$	$\pm 0.5^\circ$		Scale 比例	2:1
Tolerance Unless Stated Otherwise 未注尺寸公差								Unit 绘图单位	mm

Approved_by 批准	Julian Parker	2018/11/26
Checked_by 审核	Leo Wu	2018/11/26
Drawn_by 绘图	Cai Wangwang	2018/11/26



A

B

C

D