

HGI Part No.	27/07/2022 JTP APPROVED DOCUMENT
1120-48	

REV. 版本	ECN 工程变更通知	Description 变更描述	Name 变更人	Date 变更日期
B	ECN-HT21018	Thickness change from 2 to 1.8 according to actual	Qiu Leixin	2021/05/11
C	ECN-HT22015	The material changed from TP2 to T2	Angel Zhang	2022.7.20

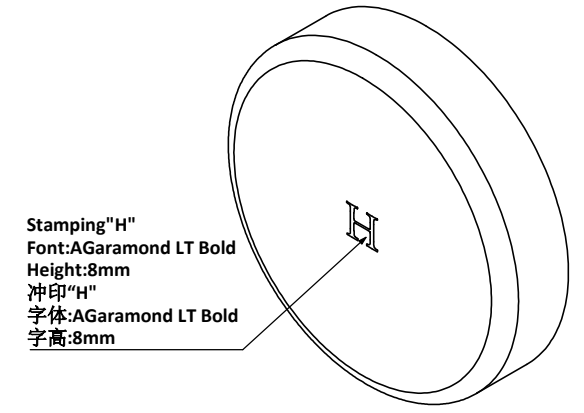
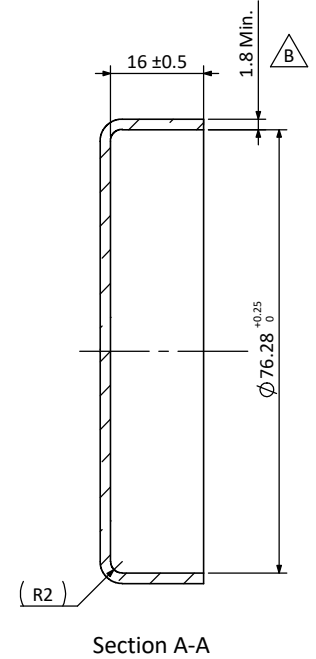
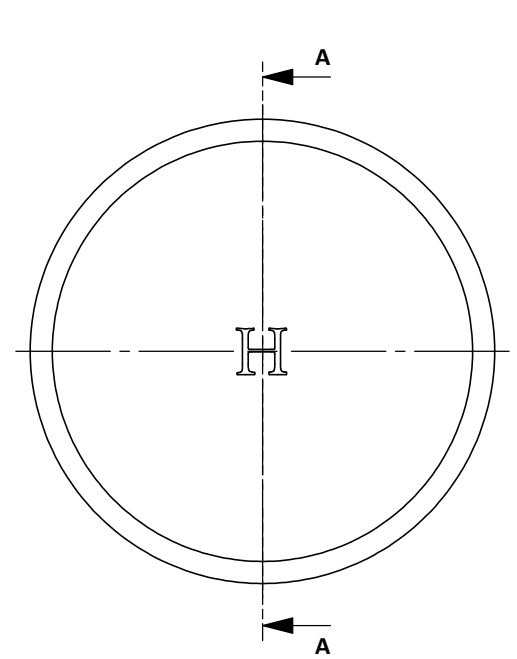

- Technical Requirement:**
技术要求:
- All edges free of burr or flash;
不能有毛刺和飞边;
 - Surface should be clean and no rust(except oil stain);
表面应干净无生锈(油渍除外);
 - Material certificates must be supplied each batch;
每批产品需提供材质分析报告;
 - Unspecified geometric tolerance according to ISO 2768-K.
未注形位公差参照ISO-2768-K执行。

Description 产品名称	Copper Stop End 3" ID 封头 3" ID		
Drawing No. 图纸编号	M040201511	REV 版次	C
Material Master No. 物料编号	040201511	Drawing Size 图幅	A4
Material 材质	T2	Sheet Number 页码	1/1
Attribute 属性	3" ID	Third Angle Projection 第三视角	

Linear Dimensions 线性尺寸	0 Decimal Place 整数	1 Decimal Place 1位小数	2 Decimal Place 2位小数	Angular Dimensions 角度尺寸	0 Decimal Place 整数	1 Decimal Place 1位小数	Ra 1.6	Estimated Weight 预估重量	138.19g
	±1.0	±0.2	±0.05		±2°	±0.5°		Scale 比例	1:1
Tolerance Unless Stated Otherwise 未注尺寸公差								Unit 绘图单位	mm

Approved_by 批准	Julian Parker	2020/8/24
Checked_by 审核	Leo Wu	2020/8/24
Drawn_by 绘图	Angel Zhang	2020/8/18

