

HGI Part No.	27/07/2022 HENRY JTP APPROVED DOCUMENT
1120Z-10	

REV. 版本	ECN 工程变更通知	Description 变更描述	Name 变更人	Date 变更日期
B	ECN-HT22015	The material changed from TP2 to T2	Angel Zhang	2022.7.20

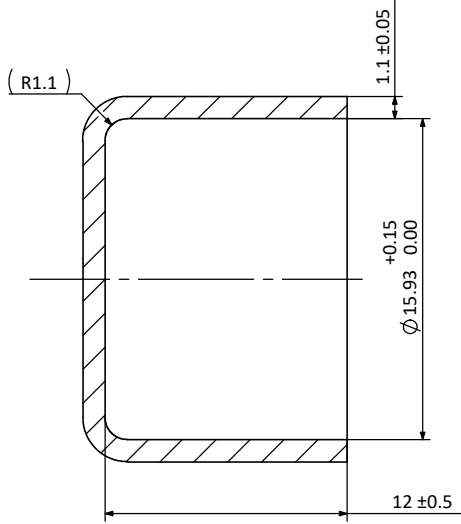

Stamping "H"
Font: AGaramond LT Bold
冲印"H"
字体:AGaramond LT Bold

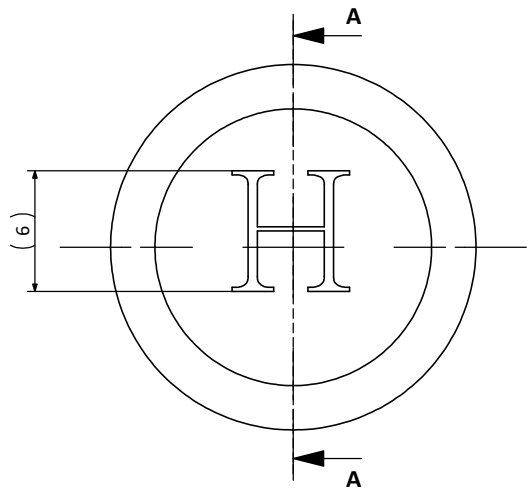
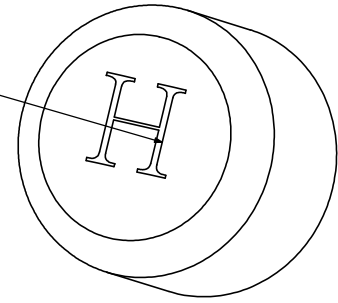

Technical requirements:

技术要求:

- Maximum of 1% ovality acceptable for the connection pockets;
承接口处椭圆度≤1%;
- Parts need to be branded according to logo requirement;
零件需按要求打印商标;
- No sharp edges or shoulders. All changes in shape must be with a smooth and suitable radius for maximum strength;
没有飞边和毛刺，所有形状改变的地方必须是平滑的并且适用于最大强度;

Description 产品名称	Stop End (CU) 5/8" ID R410A 铜封帽 5/8" ID R410A		
Drawing No. 图纸编号	M040201846	REV 版次	B
Material Master No. 物料编号	040201846	Drawing Size 图幅	A4
Material 材质	T2	Sheet Number 页码	1/1
Attribute 属性	5/8" ID	Third Angle Projection 第三视角	

Linear Dimensions 线性尺寸	0 Decimal Place 整数	1 Decimal Place 1位小数	2 Decimal Place 2位小数	Angular Dimensions 角度尺寸	0 Decimal Place 整数	1 Decimal Place 1位小数	Ra 1.6	Estimated Weight 预估重量	9.1 g
	±1.0	±0.2	±0.05		±2°	±0.5°		Scale 比例	2:1
Tolerance Unless Stated Otherwise 未注尺寸公差									

Approved_by 批准	Julian Parker	2022/7/25
Checked_by 审核	Leo Wu	2022/7/25
Drawn_by 绘图	Reuben Fan	2022/7/25

