

HGI Part No. 1120Z-12

27/07/2022 HENRY JTP APPROVED DOCUMENT

REV. 版本	ECN 工程变更通知	Description 变更描述	Name 变更人	Date 变更日期
B	ECN-HT22015	The material changed from TP2 to T2	Angel Zhang	2022.7.20

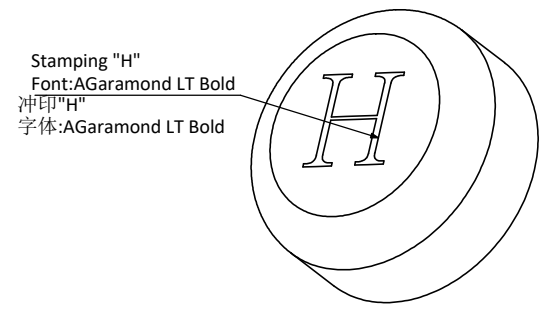
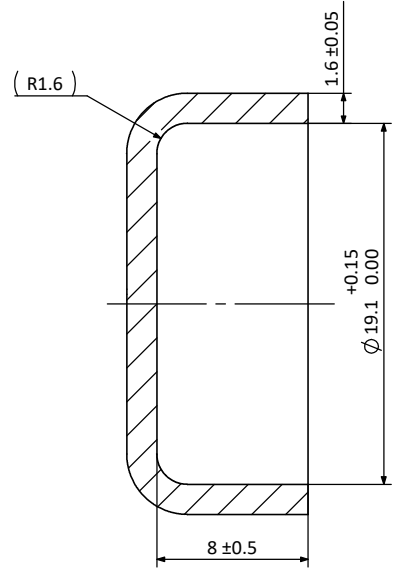
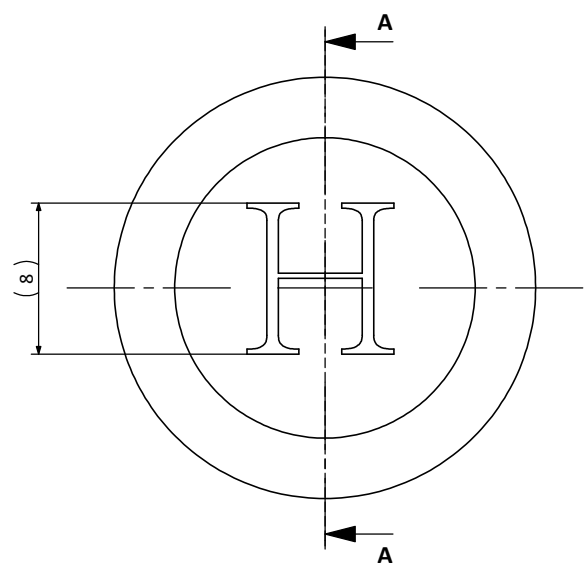

Technical requirements:

技术要求:

- Maximum of 1% ovality acceptable for the connection pockets; 承接口处椭圆度≤1%;
- Parts need to be branded according to logo requirement; 零件需按要求打印商标;
- No sharp edges or shoulders. All changes in shape must be with a smooth and suitable radius for maximum strength; 没有飞边和毛刺，所有形状改变的地方必须是平滑的并且适用于最大强度;

Description 产品名称		Stop End (CU) 3/4" ID R410A 铜封帽 3/4" ID R410A	
Drawing No. 图纸编号	M040201847	REV 版次	B
Material Master No. 物料编号	040201847	Drawing Size 图幅	A4
Material 材质	T2 $\triangle B$	Sheet Number 页码	1/1
Attribute 属性	3/4" ID	Third Angle Projection 第三视角	

Linear Dimensions 线性尺寸	0 Decimal Place 整数	1 Decimal Place 1位小数	2 Decimal Place 2位小数	Angular Dimensions 角度尺寸	0 Decimal Place 整数	1 Decimal Place 1位小数	Ra 1.6	Estimated Weight 预估重量	12.65 g
		±1.0	±0.2		±0.05			±2°	±0.5°
Tolerance Unless Stated Otherwise 未注尺寸公差								Unit 绘图单位	mm

Approved_by 批准	Julian Parker	2022/7/25
Checked_by 审核	Leo Wu	2022/7/25
Drawn_by 绘图	Reuben Fan	2022/7/25

