

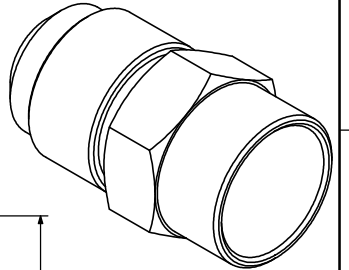

A		B			C			D	
HGI Part No.	 07/07/2020 JTP <i>silke</i> APPROVED DOCUMENT	REV.	ECN	Description		Name	Date		
208-1012		版本	工程变更通知	变更描述		变更人	变更日期		

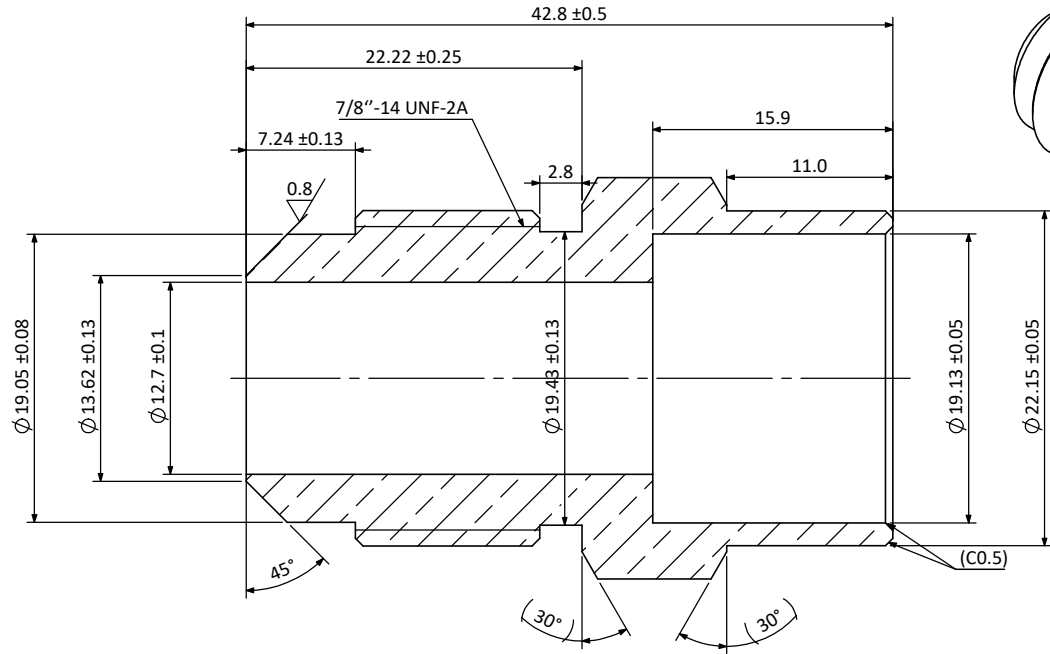
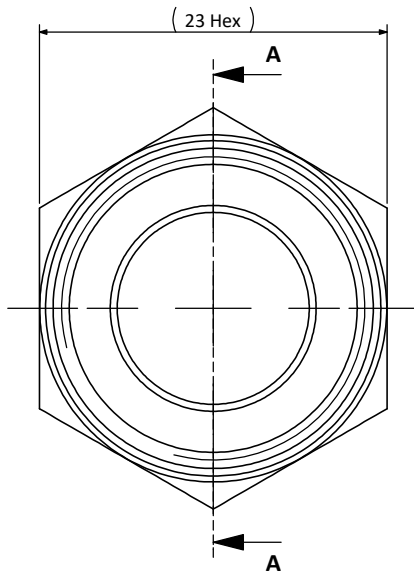

Section A-A

Technical Requirement:
技术要求:

- All edges free of burr or flash;
不能有毛刺和飞边;
- Surface should be clean and no rust(except oil stain);
表面应干净无生锈(油渍除外)
- Material certificates must be supplied each batch;
每批产品需提供材质分析报告;
- Unspecified geometric tolerance according to ISO 2768-K;
未注形位公差参照ISO-2768-K执行;
- Where is not specified,the thread must be within 1 pitch from the hex shoulder.
除有特殊说明, 螺纹到六角端面的距离应在1个螺距内;
- The hexagon opposite side must meet the outer diameter of the end.
六角对边尺寸必须满足端部外径尺寸。

Description	Union 5/8" MSAE X 3/4" ID		
产品名称	接头 5/8" MSAE X 3/4" ID		
Drawing No.	M040202188	REV	A
图纸编号		版次	
Material Master No.	040202188	Drawing Size	A4
物料编号		图幅	
Material	HPb59-1	Sheet Number	1/1
材质		页码	
Attribute	5/8" MSAE X 3/4" ID	Third Angle Projection	
属性		第三视角	

Linear Dimensions	0 Decimal Place	1 Decimal Place	2 Decimal Place	Angular Dimensions	0 Decimal Place	1 Decimal Place	Ra 1.6	Estimated Weight	67.92g
	整数	1位小数	2位小数		整数	1位小数		预估重量	67.92g
线性尺寸	±1.0	±0.2	±0.05	角度尺寸	±2°	±0.5°	Scale	2:1	
Tolerance Unless Stated Otherwise								Unit	mm
未注尺寸公差								绘图单位	mm

Approved_by	Julian Parker	2020/7/6
批准		
Checked_by	Leo Wu	2020/7/6
审核		
Drawn_by	Angel Zhang	2020/6/30
绘图		

