

HGI Part No. 209-1212

03/07/2020 HENRY
 JTP *with*
 APPROVED DOCUMENT

REV. 版本	ECN 工程变更通知	Description 变更描述	Name 变更人	Date 变更日期

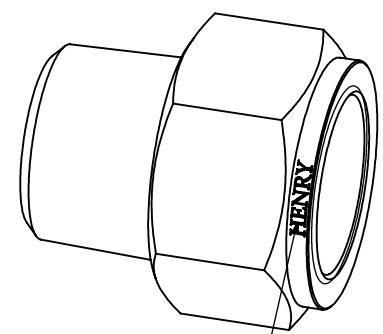
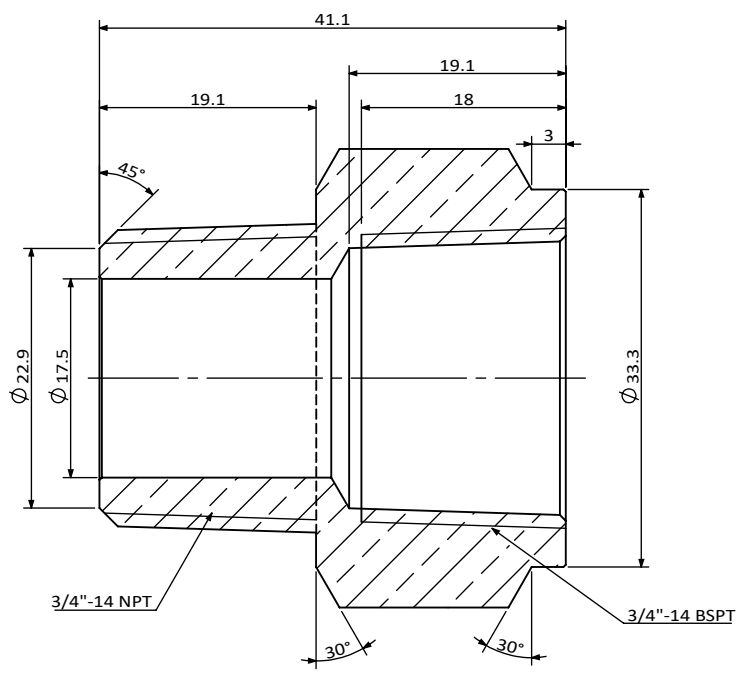
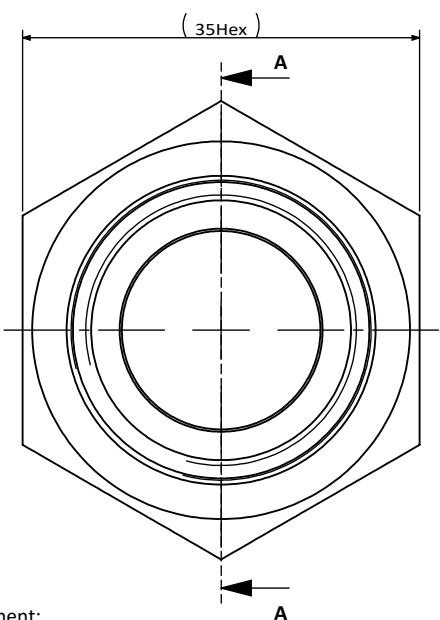

Brand "HENRY"
 Font:AGaramond LT Bold
 冲印"HENRY"
 字体:AGaramond LT Bold

Section A-A

Technical Requirement:
 技术要求:

- All edges free of burr or flash;
不能有毛刺和飞边;
- Surface should be clean and no rust(except oil stain);
表面应干净无生锈(油渍除外)
- Material certificates must be supplied each batch;
每批产品需提供材质分析报告;
- Unspecified geometric tolerance according to ISO 2768-K;
未注形位公差参照ISO-2768-K执行;
- Where is not specified,the thread must be within 1 pitch from the hex shoulder;
除有特殊说明,螺纹到六角端面的距离应在1个螺距内;
- To ensure the Logo is clear, the size of the opposite side of the hexagon shall not be smaller than the OD of the place stamped Logo.
为确保标识清晰,六角对边尺寸不能小于冲印标识处的外径。

Description 产品名称	Union 3/4" MNPT X 3/4" FBSP 接头 3/4" MNPT X 3/4" FBSP		
Drawing No. 图纸编号	M040202196	REV 版次	B
Material Master No. 物料编号	040202196	Drawing Size 图幅	A4
Material 材质	HPb59-1	Sheet Number 页码	1/1
Attribute 属性	3/4" MNPT X 3/4" FBSP	Third Angle Projection 第三视角	

Dimensions inside an oval are critical dimensions
 椭圆内尺寸为关键尺寸

Linear Dimensions 线性尺寸	0 Decimal Place 整数	1 Decimal Place 1位小数	2 Decimal Place 2位小数	Angular Dimensions 角度尺寸	0 Decimal Place 整数	1 Decimal Place 1位小数	Ra 1.6	Estimated Weight 预估重量	164.38g	
	±1.0	±0.2	±0.05		±2°	±0.5°		Scale 比例	1.5:1	Unit 绘图单位
Tolerance Unless Stated Otherwise 未注尺寸公差								Approved_by 批准	Julian Parker	2020/06/28
								Checked_by 审核	Leo Wu	2020/06/28
								Drawn_by 绘图	Zhou Lei	2020/06/22

