

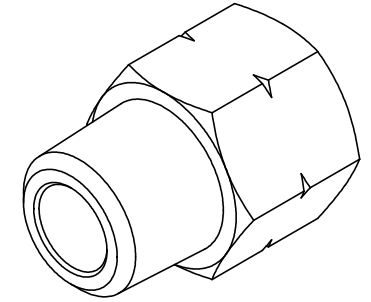

A		B			C			D	
HGI Part No.	07/07/2020  JTP <i>silke</i> APPROVED DOCUMENT	REV.	ECN	Description			Name	Date	
210-0808		版本	工程变更通知	变更描述			变更人	变更日期	

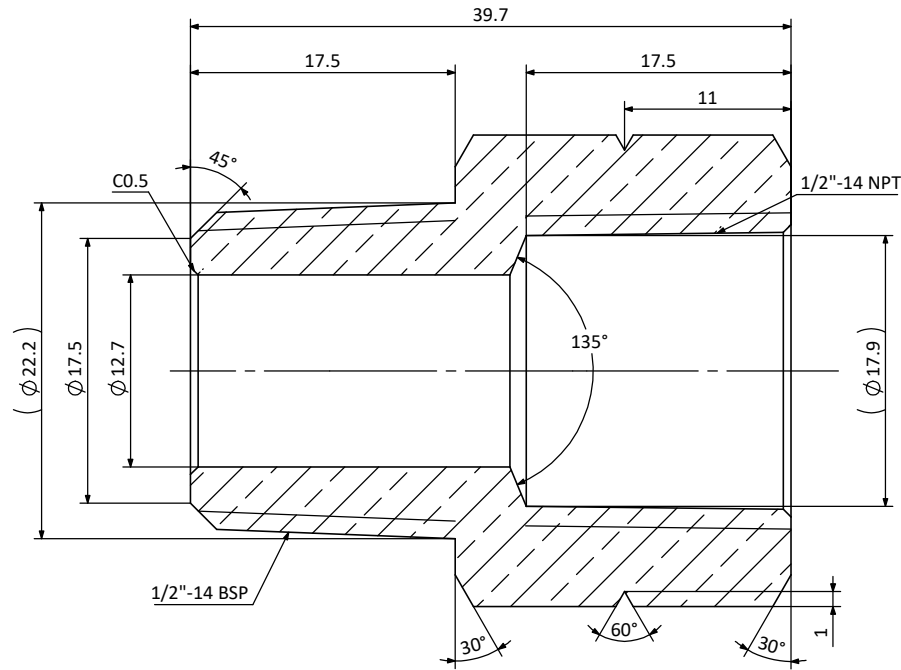
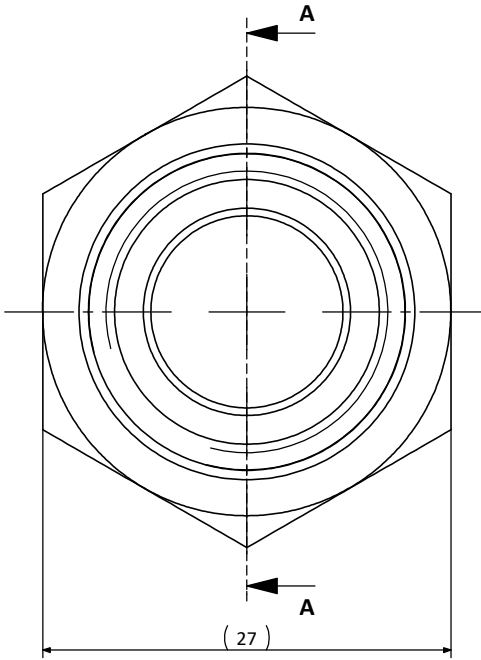

Section A-A

Technical Requirements:
技术要求:

- All edges free of burr or flash, 不能有毛刺和飞边;
- Where is not specified, the thread must be within 1 thread pitch from the hex shoulder, 除有特别说明, 螺纹到六角端面的距离应在一个螺距内;
- Unspecified geometric tolerance according to ISO 2768-K. 未注形位公差参照ISO 2768-K执行。

Description 产品名称		Union 1/2" FNPT×1/2" MBSP 接头 1/2" FNPT×1/2" MBSP	
Drawing No. 图纸编号	M040202199	REV 版次	A
Material Master No. 物料编号	040202199	Drawing Size 图幅	A4
Material 材质	HPb59-1	Sheet Number 页码	1/1
Attribute 属性	1/2" FNPT×1/2" MBSP	Third Angle Projection 第三视角	

Dimensions inside an oval are critical dimensions
椭圆内尺寸为关键尺寸

Linear Dimensions 线性尺寸	0 Decimal Place 整数	1 Decimal Place 1位小数	2 Decimal Place 2位小数	Angular Dimensions 角度尺寸	0 Decimal Place 整数	1 Decimal Place 1位小数	Ra 1.6 	Estimated Weight 预估重量	107g
	±1.0	±0.2	±0.05		±2°	±0.5°		Scale 比例	2:1
Tolerance Unless Stated Otherwise 未注尺寸公差								Unit 绘图单位	mm

Approved_by 批准	Julian Parker	2020/07/03
Checked_by 审核	Leo Wu	2020/07/03
Drawn_by 绘图	Qiu Leixin	2020/07/03



1

2

3

4

1

2

3

4

A

B

C

D