

REV. 版本	ENC 工程变更通知	Description 变更描述	Name 变更人	Date 变更日期

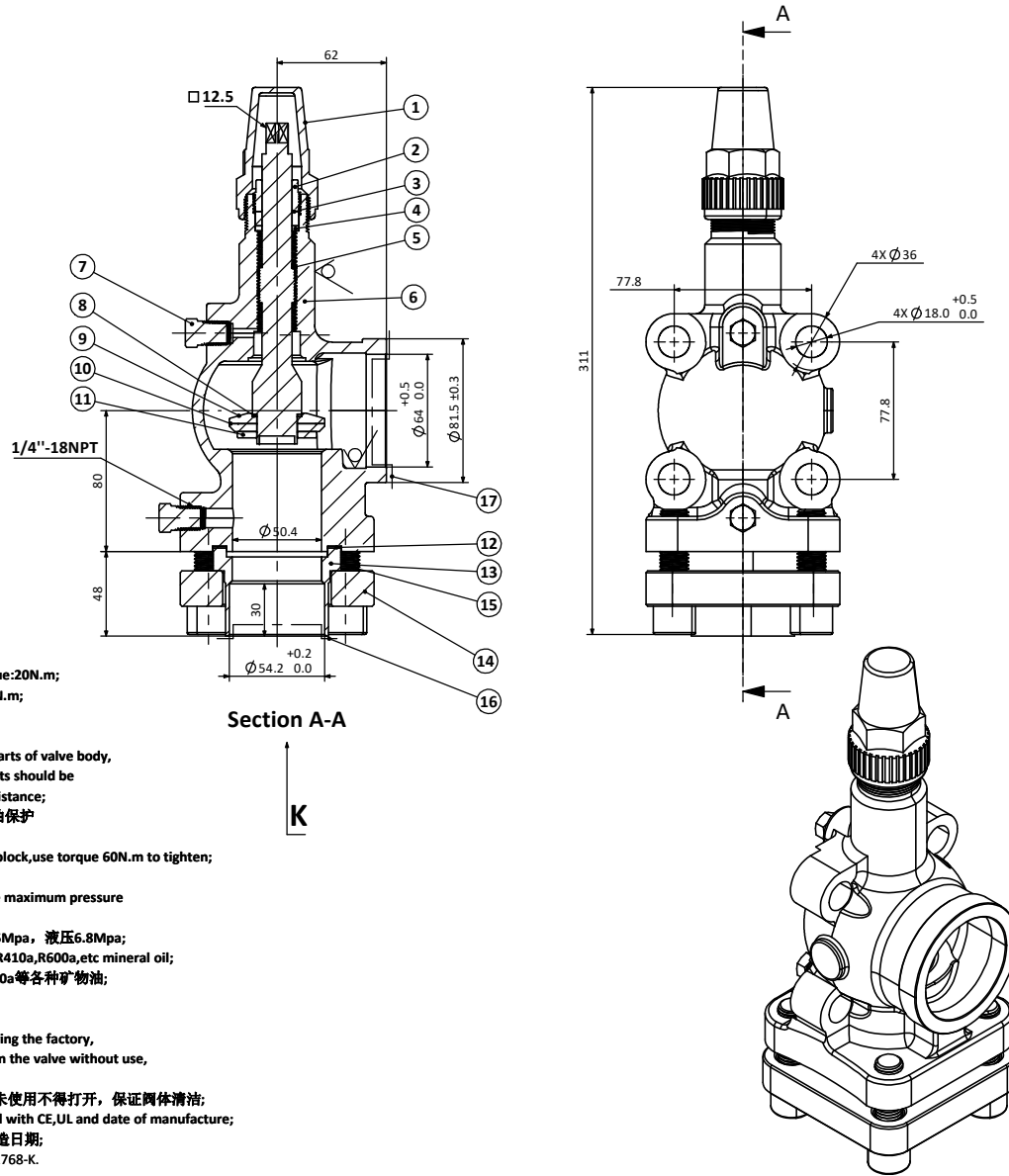

Technical Requirements:

技术要求:

- The torque of fastening fixed bolt:69.1N.m;
 紧固固定螺栓的扭矩为69.1N.m;
- Turn the stem off clockwise and turn on using torque:20N.m;
 将阀杆顺时针方向关闭,反之开启使用扭矩为20N.m;
- Torque of flange connection bolt 48.7N.m;
 法兰接管固定螺栓的扭矩为48.7N.m;
- Do not rust, scratch or bruise internal or external parts of valve body,
 Slightly apply rust - proof oil for protection,The parts should be
 flexible when rotating after assembly ,no stuck resistance;
 阀体内外零件不得生锈,划伤,碰伤,稍微涂防锈油保护
 装配完成后零件转动时应灵活,没有卡阻现象;
- Pre-painted clorotex 554 glue when installing wire block,use torque 60N.m to tighten;
 装丝堵时预涂乐泰554胶水,使用扭矩60N.m扭紧;
- Valve body assembly after the air tightness test,the maximum pressure
 is 4.5mpa and the hydraulic pressure is 6.8mpa;
 阀体装配后需经气密测试,使用最大压力为气压4.5Mpa, 液压6.8Mpa;
- Applicable medium:R22,R502,R407c,R134a,R404a,R410a,R600a,etc mineral oil;
 适用介质:R22,R502,R407c,R134a,R404a,R410a,R600a等各种矿物油;
- Use medium temperature:-40°C~140°C;
 使用流体介质温度:-40°C~140°C;
- The valve stem should be in 1/4 position when leaving the factory,
 and the whole is sealed with plastic bag,do not open the valve without use,
 Ensure the valve body is clean;
 出厂时阀杆应在1/4位置,整体用塑料袋密封包装,未使用不得打开, 保证阀体清洁;
- Store in a cool, dry place,the body shall be marked with CE,UL and date of manufacture;
 在阴凉干燥处存放,阀体上须刻有CE,UL标记及制造日期;
- Unspecified geometric tolerance according to ISO 2768-K.
 未注形位公差参照ISO 2768-K.

17	Median Plug 中塞	PVC	1
16	Plug 塞嘴	PVC	1
15	Bolt 内六角螺栓	45#	4
14	Flange 法兰	25#	1
13	Connecting Tube 接管	20#	1
12	Sealing Ring 密封垫片	AFM34	1
11	Valve Head Tablet 阀头压片	45#	1
10	Valve Head Sealing Ring 阀头密封圈	PTFE	1
9	Valve Head 阀头	45#	1
8	Sealing Ring 密封垫片	PTFE	1
7	Plug 丝堵	HPB59-1	2
6	Valve Body 阀体	QT500-7	1
5	Spindle 阀杆	45#	1
4	Gland Follower 填料垫片	20#	1
3	Gland 填料	PTFE	2
2	Gland Nut 填料螺母	45#	1
1	Plastic Cap 帽盖	PA66	1
Item 序号	Description 描述	Material 材质	QTY 数量
Description 产品名称		Compressor Service Valve C/W Plug 2-1/8" ODS 压缩机维修阀带 2-1/8" ODS	
Drawing No. 图纸编号	M050509973	REV 版次	A
Material Master No. 物料编号	050509973	Drawing Size 图幅	A3
Material 材质	See Table	Sheet Number 页码	1/1
Attribute 属性	2-1/8" ODS	Third Angle Projection 第三视角	

Dimensions inside an oval
are critical dimensions
椭圆内尺寸为关键尺寸

Linear Dimensions
线性尺寸 (mm)

0 Decimal Place
整数 ±1.0

1 Decimal Place
1位小数 ±0.2

2 Decimal Place
2位小数 ±0.05

Angular Dimensions
角度尺寸 ±2°

1 Decimal Place
1位小数 ±0.5°

1.6
Ra

Estimated Weight
预估重量

Scale
比例 1:5

Unit
绘图单位 mm

N/A

Approved_by
批准

Julian Parker

2018/11/16

Checked_by
审核

Leo Wu

2018/11/16

Drawn_by
绘图

Angel Zhang

2018/11/16

