

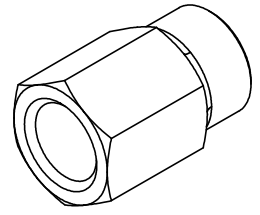

A		B			C			D	
HGI Part No.	 03/07/2020 JTP <i>silke</i> APPROVED DOCUMENT	REV.	ECN	Description		Name	Date		
233-0408		版本	工程变更通知	变更描述		变更人	变更日期		

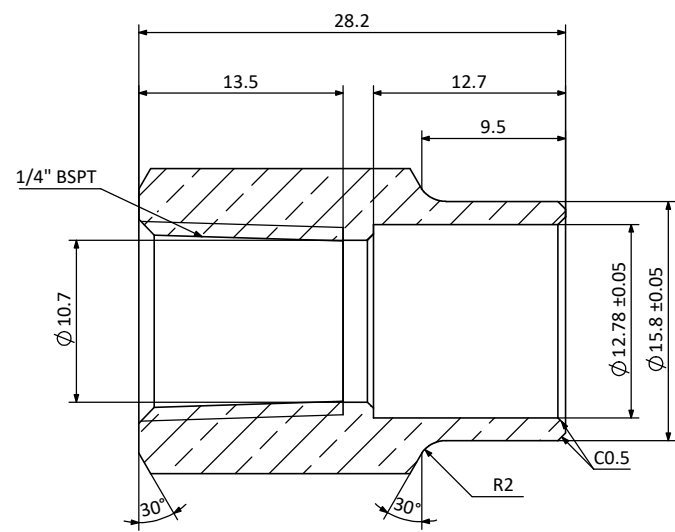
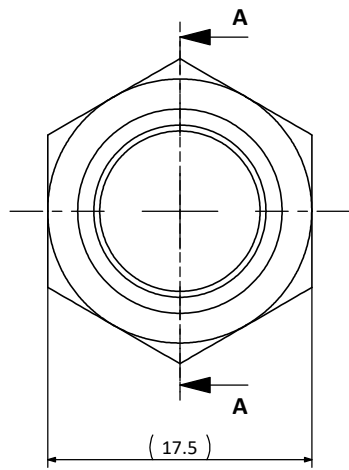

Section A-A

Technical Requirements:

- 技术要求:
- All edges free of burr or flash, 不能有毛刺和飞边;
  - Forged parts to have hex faces broached for a machined finish, 零件由六角锻件加工而成;
  - Unspecified geometric tolerance according to ISO 2768-K. 未注形位公差参照ISO 2768-K执行。

Description		Union 1/4" FBSPT×1/2" ID	
产品名称		接头 1/4" FBSPT×1/2" ID	
Drawing No.	M040202275	REV	A
图纸编号		版次	
Material Master No.	040202275	Drawing Size	A4
物料编号		图幅	
Material	HPb59-1	Sheet Number	1/1
材质		页码	
Attribute	1/4" FBSPT×1/2" ID	Third Angle Projection	
属性		第三视角	

Linear Dimensions		Angular Dimensions		Estimated Weight		Scale		Unit	
0 Decimal Place	1 Decimal Place	2 Decimal Place	0 Decimal Place	1 Decimal Place	Estimated Weight	N/A	Scale	Unit	mm
整数	1位小数	2位小数	整数	1位小数	预估重量	N/A	比例	绘图单位	mm
±1.0	±0.2	±0.05	±2°	±0.5°			2:1		
Tolerance Unless Stated Otherwise					未注尺寸公差				

