

HGI Part No. 17/04/2020 HENRY JTP APPROVED DOCUMENT

300-0404

REV. 版本	ECN 工程变更通知	Description 变更描述	Name 变更人	Date 变更日期
B	ECN-HT20021	Change the shape of the part according to the actual incoming material	Angel Zhang	2020.4.17

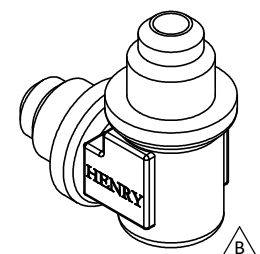
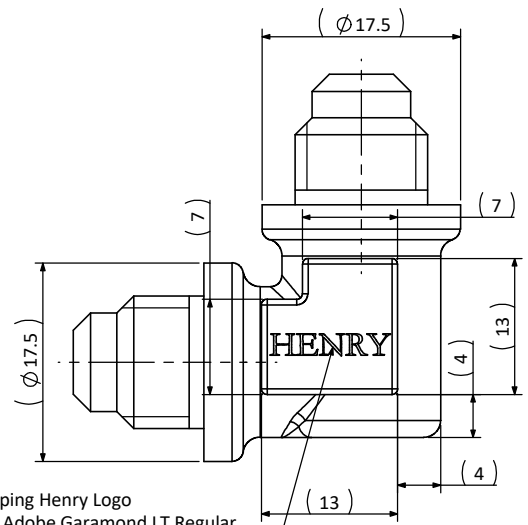
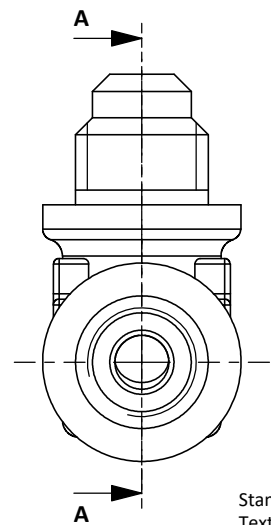
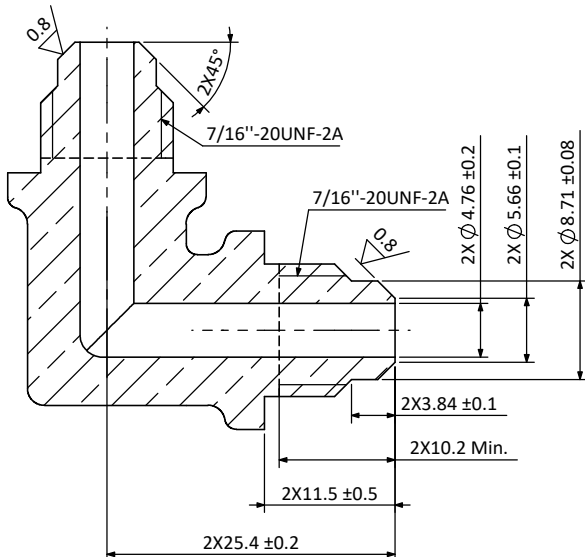

Stamping Henry Logo
Text: Adobe Garamond LT Regular
Text height: 2.0mm
冲印Henry商标
字体: Adobe Garamond LT Regular
字高: 2.0mm

- Technical Requirement:
技术要求:
- All edges free of burr or flash;
不能有毛刺和飞边;
 - Surface should be clean and no rust(except oil stain);
表面应干净无生锈(油渍除外);
 - Material certificates must be supplied each batch;
每批产品需提供材质分析报告;
 - Unspecified geometric tolerance according to ISO 2768-K.
未注形位公差参照ISO-2768-K执行。
 - Make from forging:300-0606F;
用300-0606F毛坯制造;
 - Where is not specified,the thread must be within 1 thread pitch from the hex shoulder.
除有特别说明,螺纹到六角端面的距离应在一个螺纹内。

Dimensions inside an oval are critical dimensions
椭圆内尺寸为关键尺寸

Description 产品名称	Elbow 1/4" MSAE x 1/4" MSAE 弯头 1/4" MSAE x 1/4" MSAE		
Drawing No. 图纸编号	M040202295	REV 版次	B
Material Master No. 物料编号	040202295	Drawing Size 图幅	A4
Material 材质	HPb59-1	Sheet Number 页码	1/1
Attribute 属性	N/A	Third Angle Projection 第三视角	

Linear Dimensions 线性尺寸	0 Decimal Place 整数	1 Decimal Place 1位小数	2 Decimal Place 2位小数	Angular Dimensions 角度尺寸	0 Decimal Place 整数	1 Decimal Place 1位小数	Ra 1.6	Estimated Weight 预估重量	53.57g		
	±1.0	±0.2	±0.05		±2°	±0.5°		Scale 比例	2:1	Unit 绘图单位	mm
Tolerance Unless Stated Otherwise 未注尺寸公差									Approved_by 批准	Julian Parker	2020/4/17
									Checked_by 审核	Leo Wu	2020/4/17
									Drawn_by 绘图	Angel Zhang	2020/4/9

