

HGI Part No.
300-1010

07/09/2022 HENRY
JTP APPROVED DOCUMENT

REV. 版本	ECN 工程变更通知	Description 变更描述	Name 变更人	Date 变更日期
B	ECN-HT22016	Update according to actual	Qiu Leixin	2022/8/20

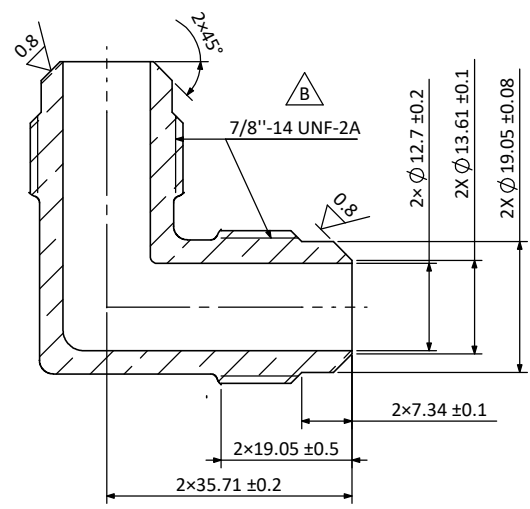

Section A-A

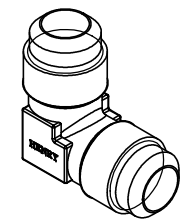
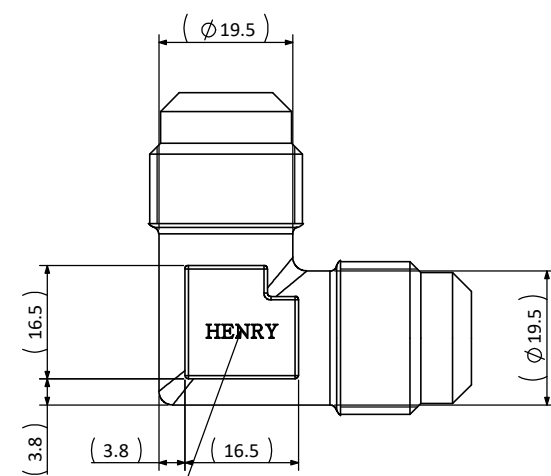
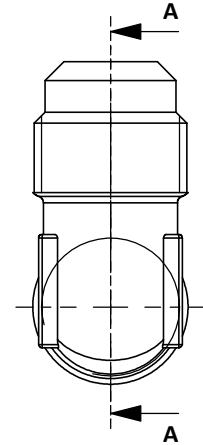

Stamping Henry Logo
Text: Adobe Garamond LT Regular
Text height: 2.0mm
冲印Henry商标
字体: Adobe Garamond LT Regular
字高: 2.0mm

- Technical Requirement:
技术要求:
- All edges free of burr or flash;
不能有毛刺和飞边;
 - Surface should be clean and no rust(except oil stain);
表面应干净无生锈(油渍除外);
 - Material certificates must be supplied each batch;
每批产品需提供材质分析报告;
 - Unspecified geometric tolerance according to ISO 2768-K.
未注形位公差参照ISO-2768-K执行。
 - Make from forging:300-1010F;
用300-1010F毛坯制造;
 - Where is not specified,the thread must be within 1 thread pitch from the hex shoulder.
除有特别说明, 螺纹到六角端面的距离应在一个螺距内。

Description 产品名称	Elbow 5/8 MSAE × 5/8 MSAE 弯头 5/8 MSAE × 5/8 MSAE		
Drawing No. 图纸编号	M040202299	REV 版次	B
Material Master No. 物料编号	040202299	Drawing Size 图幅	A4
Material 材质	HPb59-1	Sheet Number 页码	1/1
Attribute 属性	N/A	Third Angle Projection 第三视角	

Linear Dimensions 线性尺寸	0 Decimal Place 整数	1 Decimal Place 1位小数	2 Decimal Place 2位小数	Angular Dimensions 角度尺寸	0 Decimal Place 整数	1 Decimal Place 1位小数	Ra 1.6	Estimated Weight 预估重量	122.68g
	±1.0	±0.2	±0.05		±2°	±0.5°		Scale 比例	1:1
Tolerance Unless Stated Otherwise 未注尺寸公差									

Approved_by 批准	Julian Parker	2021/8/16
Checked_by 审核	Leo Wu	2021/8/16
Drawn_by 绘图	Qiu Leixin	2021/8/16



A

B

C

D