

HGI Part No.
3210-9622-customer

09/10/2019 HENRY
JTP *skll*
APPROVED DOCUMENT

PED 2014/68/EU AS2971.2 UL207
 CAT I CAT II

REV. 版本	ECN 工程变更通知	Description 变更描述	Name 变更人	Date 变更日期

Volume Ltrs	Shell ID mm	Design Pressure MPa	Leak Test Pressure MPa	Proof Test Pressure MPa	Min Burst Test Pressure MPa
6.2	Ø150	3.2	3.2	4.6	14.08

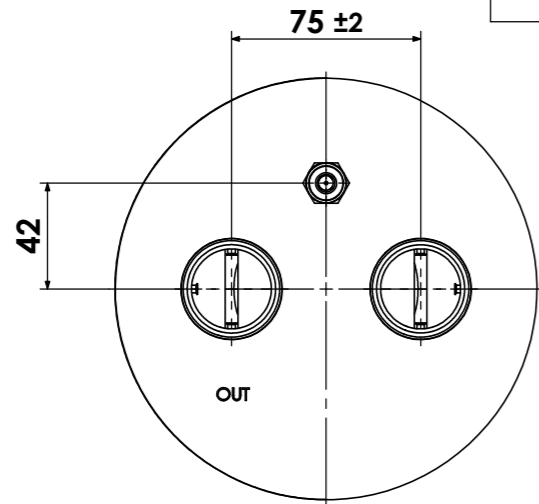

1 3/8" ODS Copper Outlet 1 3/8" ODS Copper Inlet

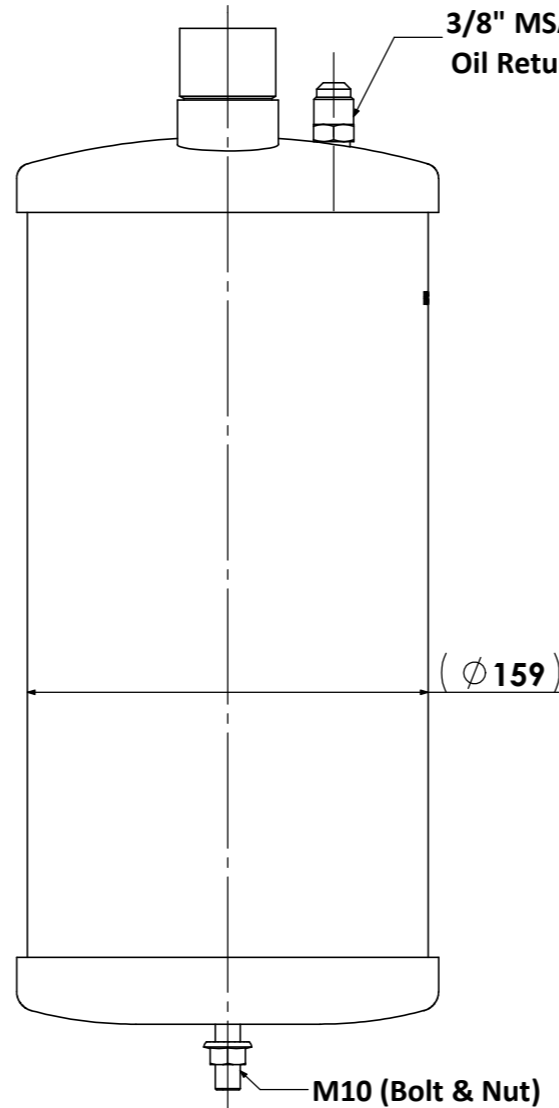
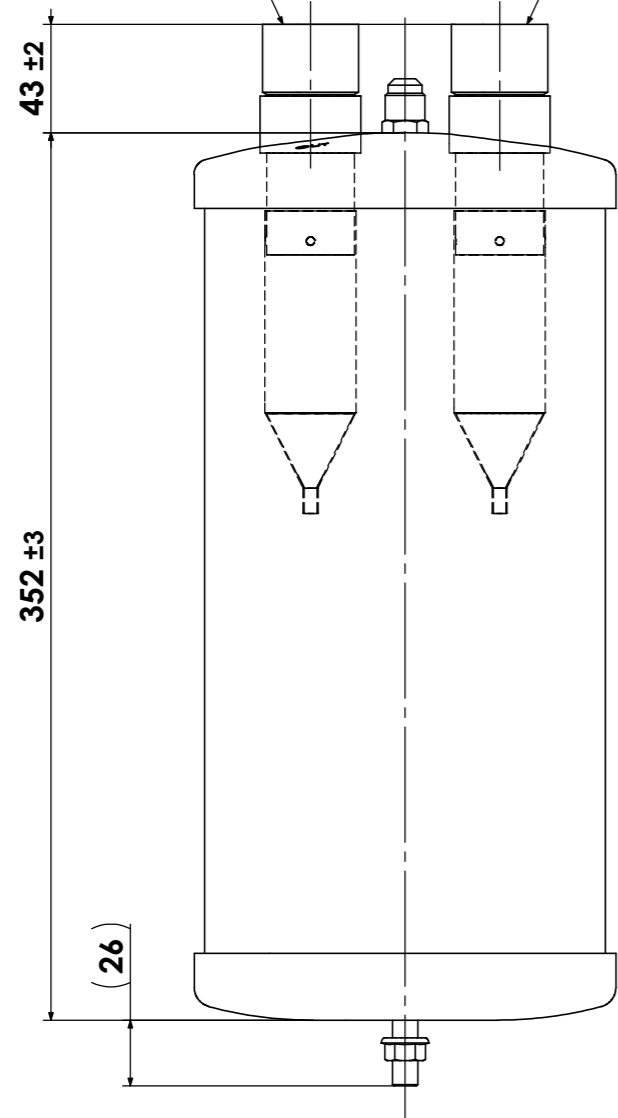

Stamp manufacturing code and date code
冲印工厂代码和制造日期

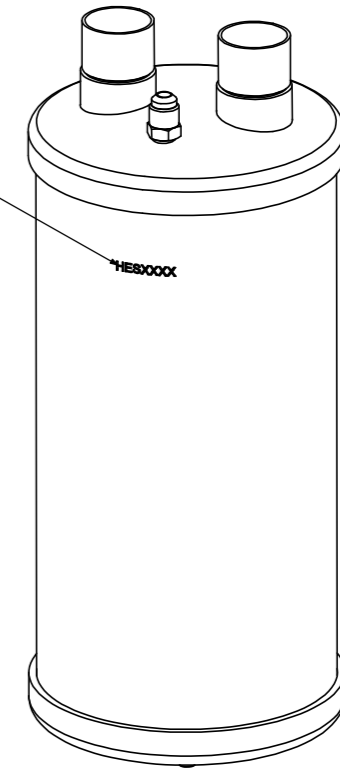

ISO 1:4

Technical Requirements:

技术要求

1. Allowable operating temperature -10°C to +130°C;
工作温度-10°C到+130°C;
2. Powder coating: Henry Blue RAL 5013.
喷涂颜色: 亨利蓝RAL 5013.

Description 产品名称	Oil Separator 1 3/8" ID x 3/8" MSAE 油分离器 1 3/8" ID x 3/8" MSAE		
Drawing No. 图纸编号	M050505142	REV 版次	A
Material Master No. 物料编号	050505142	Drawing Size 图幅	A3
Material 材质	N/A	Sheet Number 页码	1/1
Attribute 属性	1 3/8" ID	Third Angle Projection 第三视角	

Dimensions inside an oval
are critical dimensions
椭圆内尺寸为关键尺寸

Linear Dimensions 线性尺寸 (mm)	0 Decimal Place 整数	1 Decimal Place 1位小数	2 Decimal Place 2位小数	Angular Dimensions 角度尺寸	0 Decimal Place 整数	1 Decimal Place 1位小数	Estimated Weight 预估重量	Scale 比例	Unit 绘图单位
	±1.0	±0.2	±0.05		±2°	±0.5°			

Tolerance Unless Stated Otherwise
未注尺寸公差

Approved_by 批准	Julian Parker	2019/10/9
Checked_by 审核	Leo Wu	2019/10/9
Drawn_by 绘图	Nancy Huang	2019/9/11

