

HGI Part No. 3210-9626-customer	09/10/2019 HENRY JTP APPROVED DOCUMENT	<input checked="" type="checkbox"/> PED 2014/68/EU <input checked="" type="checkbox"/> AS2971.2 <input type="checkbox"/> UL207				REV. 版本	ECN 工程变更通知	Description 变更描述	Name 变更人	Date 变更日期
		<input type="checkbox"/> CAT I <input type="checkbox"/> CAT II <input checked="" type="checkbox"/> CAT III	Volume Ltrs	Shell ID mm	Design Pressure MPa	Leak Test Pressure MPa	Proof Test Pressure MPa	Min Burst Test Pressure MPa		
		7.12	Ø150	3.2	3.2	4.6	14.08			

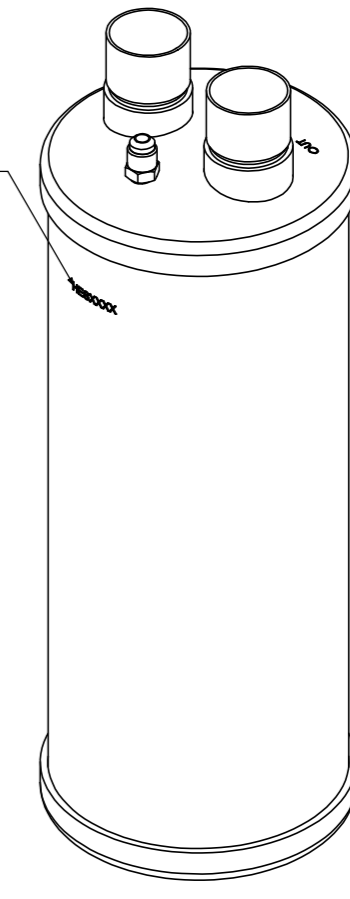
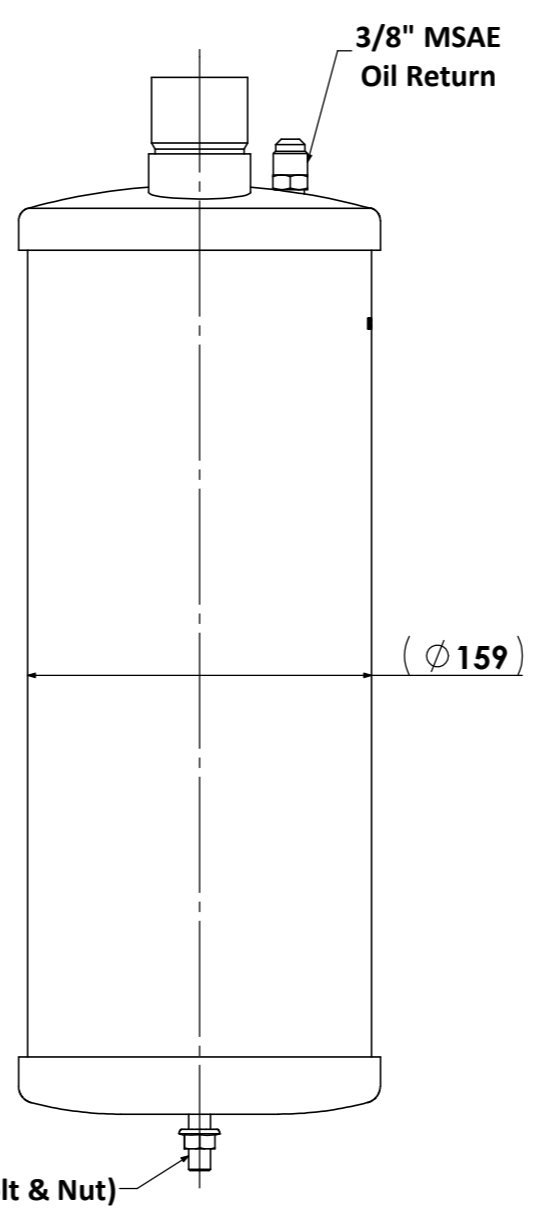
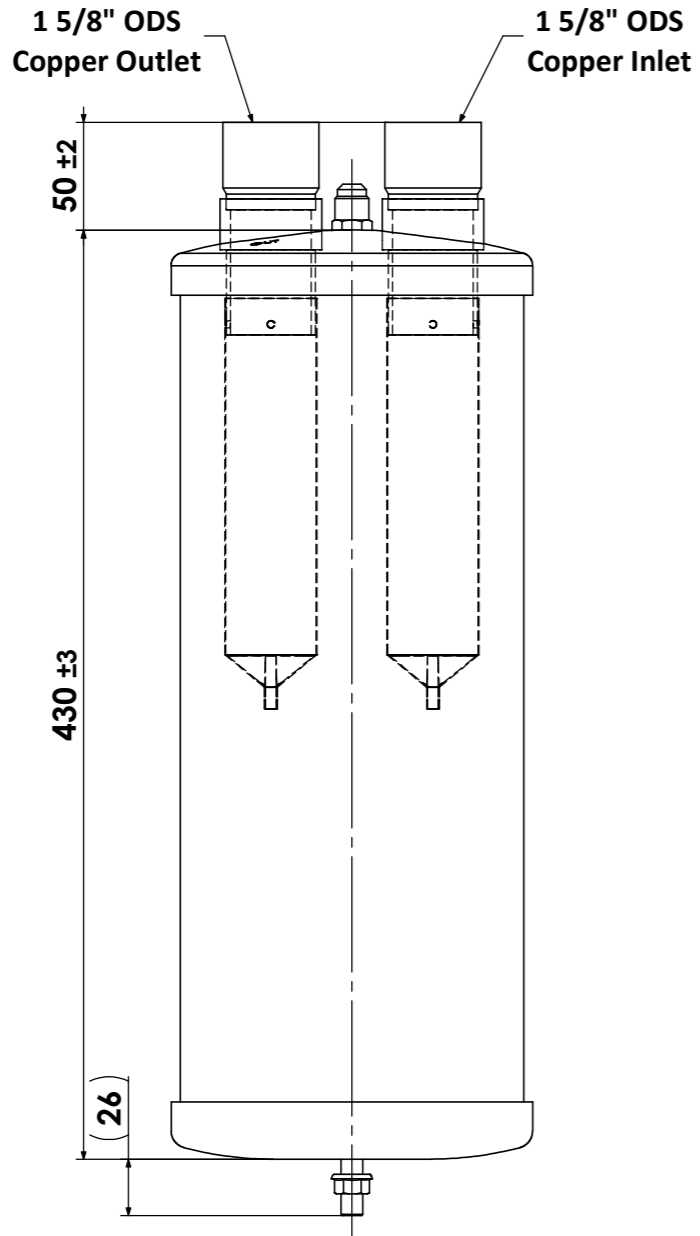
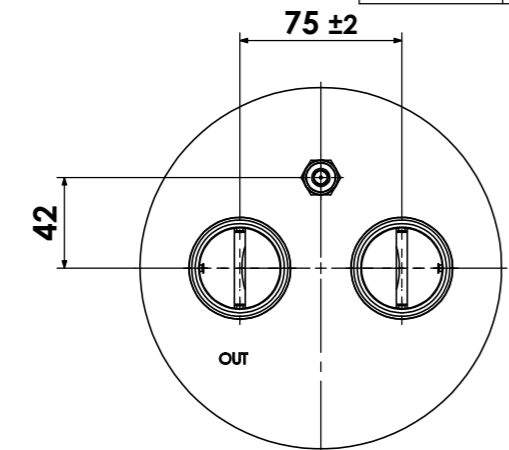

Stamp manufactory code and date code
冲印工厂代码和制造日期

ISO 1:4

- Technical Requirements:**
技术要求
1. Allowable operating temperature -10°C to +130°C;
工作温度-10°C到+130°C;
 2. Powder coating: Henry Blue RAL 5013.
喷涂颜色: 亨利蓝RAL 5013.

Description 产品名称	Oil Separator 1 5/8" ID x 3/8" MSAE 油分离器 1 5/8" ID x 3/8" MSAE		
Drawing No. 图纸编号	M050505144	REV 版次	A
Material Master No. 物料编号	050505144	Drawing Size 图幅	A3
Material 材质	N/A	Sheet Number 页码	1/1
Attribute 属性	1 5/8" ID x 3/8" MSAE	Third Angle Projection 第三视角	

Dimensions inside an oval are critical dimensions 椭圆内尺寸为关键尺寸	Linear Dimensions 线性尺寸 (mm)	0 Decimal Place 整数	1 Decimal Place 1位小数	2 Decimal Place 2位小数	Angular Dimensions 角度尺寸	0 Decimal Place 整数	1 Decimal Place 1位小数	Ra 1.6	Estimated Weight 预估重量	N/A	Approved_by 批准	Julian Parker	2019/10/9	
		±1.0	±0.2	±0.05		±2°	±0.5°		Scale 比例	1:3.5	Checked_by 审核	Leo Wu	2019/10/9	
Tolerance Unless Stated Otherwise 未注尺寸公差									Unit 绘图单位	mm	Drawn_by 绘图	Nancy Huang	2019/9/12	