

HGI Part No. 502-0806

10/01/2019 HENRY JTP APPROVED DOCUMENT

REV. 版本	ENC 工程变更通知	Description 变更描述	Name 变更人	Date 变更日期
B	ECN-HT19003	7±0.5 was 8±0.25	Angel Zhang	2019.1.8

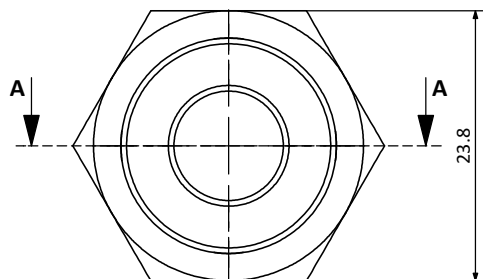
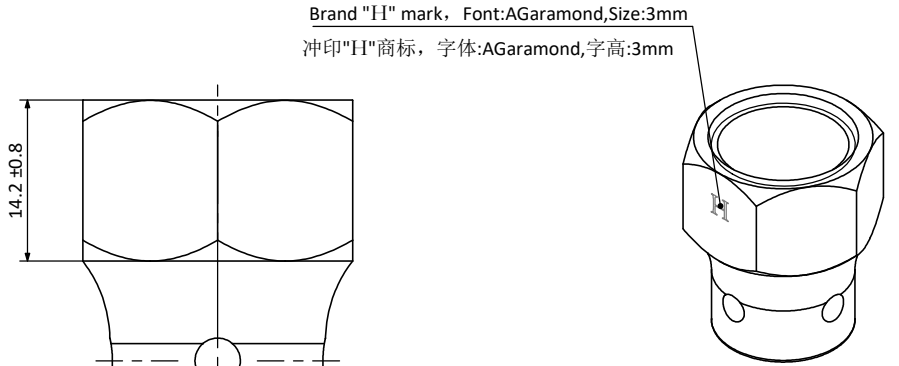
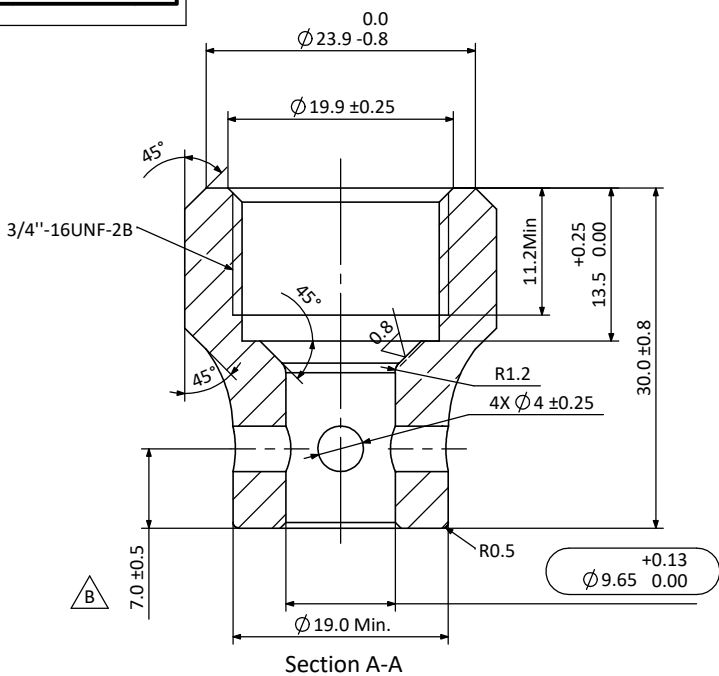

Technical Requirements: 技术要求:

- All edges free of burr or flash; 不能有毛刺和飞边;
- Part to conform to SAE J513; 零件符合SAE J513标准;
- Material certificates must be supplied with every batch; 每批产品需提供材质分析报告;
- Unspecified geometric tolerance according to ISO 2768-K. 未注形位公差参照ISO 2768-K.

Description 产品名称		Flare Nut Frost Proof 1/2FSAEx3/8"ID 防冻纳子 1/2FSAEx3/8"ID	
Drawing No. 图纸编号	M040202420	REV 版次	B
Material Master No. 物料编号	040202420	Drawing Size 图幅	A4
Material 材质	HPb59-1	Sheet Number 页码	1/1
Attribute 属性	1/2FSAEx3/8"ID	Third Angle Projection 第三视角	

Linear Dimensions 线性尺寸	0 Decimal Place 整数	1 Decimal Place 1位小数	2 Decimal Place 2位小数	Angular Dimensions 角度尺寸	0 Decimal Place 整数	1 Decimal Place 1位小数	Ra 1.6	Estimated Weight 预估重量	59.01g
	±1.0	±0.2	±0.05		±2°	±0.5°			
Tolerance Unless Stated Otherwise 未注尺寸公差								Scale 比例	2:1
								Unit 绘图单位	mm

Approved_by 批准	Julian Parker	2019/1/9
Checked_by 审核	Leo Wu	2019/1/9
Drawn_by 绘图	Angel Zhang	2019/1/9



A

B

C

D