

HGI Part No.	26/04/2019 HENRY JTP APPROVED DOCUMENT
502-1210	

REV. 版本	ENC 工程变更通知	Description 变更描述	Name 变更人	Date 变更日期
B	ECN-HT18055	Change Logo to "H" mark	Li.Dongsen	2019/03/20

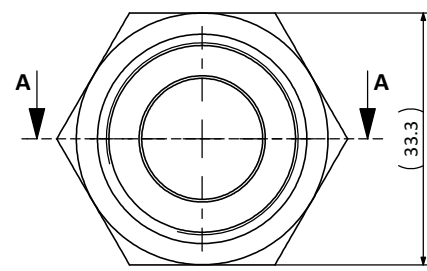
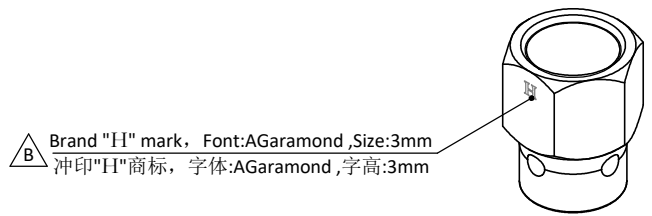
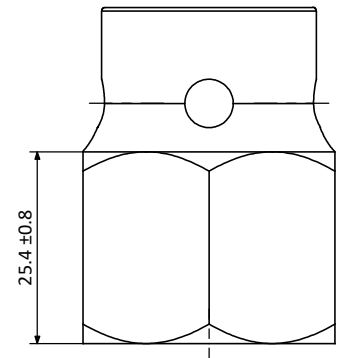
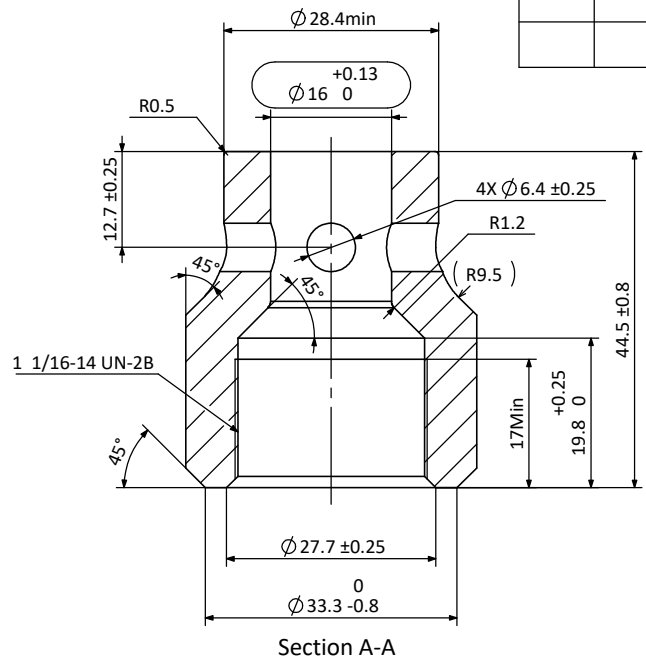

Technical Requirements:
技术要求:

- All edges free of burr or flash;
不能有毛刺和飞边;
- Part to conform to SAE J513;
零件符合SAE J513标准;
- Material certificates must be supplied with every batch;
每批产品需提供材质分析报告;
- Unspecified geometric tolerance according to ISO 2768-K.
未注形位公差参照ISO 2768-K;
- All parts to be forged, these should never be machined from bar stock.
The forging should be accurate enough.
部件必须是锻造而成, 不能棒料加工。锻造毛坯需保证足够精度。

Dimensions inside an oval are critical dimensions
椭圆内尺寸为关键尺寸

Linear Dimensions 线性尺寸	0 Decimal Place 整数	1 Decimal Place 1位小数	2 Decimal Place 2位小数	Angular Dimensions 角度尺寸	0 Decimal Place 整数	1 Decimal Place 1位小数	Ra 1.6 	Estimated Weight 预估重量	178.03g
	±1.0	±0.2	±0.05		±2°	±0.5°		Scale 比例	1:1
Tolerance Unless Stated Otherwise 未注尺寸公差								Unit 绘图单位	mm

Description 产品名称		Flare Nut Frost Proof 3/4 FSAE x 5/8" ID 防冻纳子 3/4 FSAE x 5/8" ID		
Drawing No. 图纸编号	M040202423	REV 版次	B	
Material Master No. 物料编号	040202423	Drawing Size 图幅	A4	
Material 材质	HPb59-1	Sheet Number 页码	1/1	
Attribute 属性	3/4 FSAE x 5/8" ID	Third Angle Projection 第三视角		

Approved_by 批准	Julian Parker	2019/03/20	
Checked_by 审核	Leo Wu	2019/03/20	
Drawn_by 绘图	Li.Dongsen	2019/03/20	