

REV. 版本	ENC 工程变更通知	Description 变更描述	Name 变更人	Date 变更日期
B	ECN-HT18055	Change Logo to "H" mark	Li.Dongsen	2019/03/20

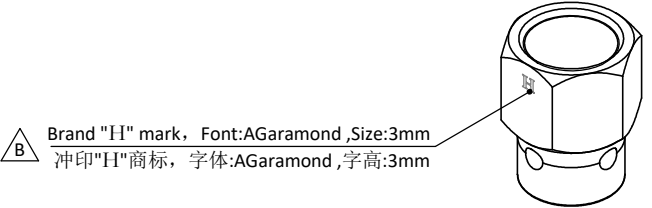
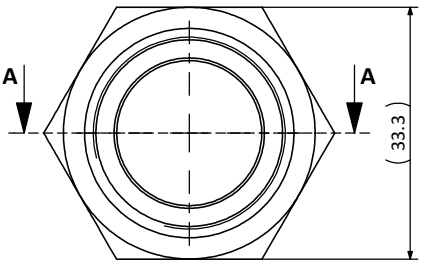
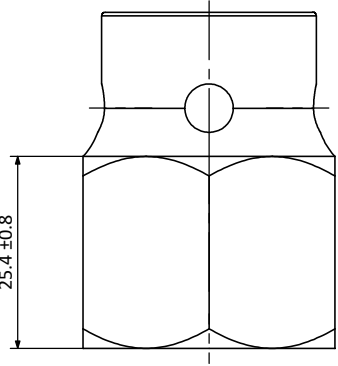
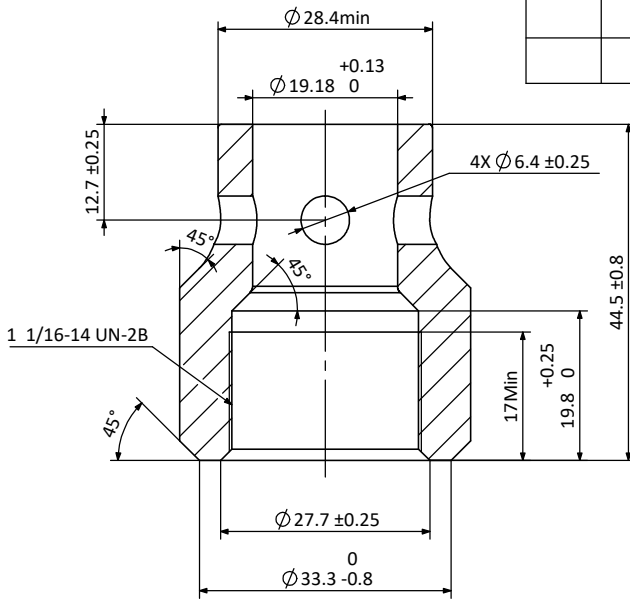

Technical Requirements:

- 技术要求:
- All edges free of burr or flash; 不能有毛刺和飞边;
 - Part to conform to SAE J513; 零件符合SAE J513标准;
 - Material certificates must be supplied with every batch; 每批产品需提供材质分析报告;
 - Unspecified geometric tolerance according to ISO 2768-K. 未注形位公差参照ISO 2768-K;
 - All parts to be forged, these should never be machined from bar stock. The forging should be accurate enough. 部件必须是锻造而成, 不能棒料加工。锻造毛坯需保证足够精度。

Description 产品名称	Flare Nut Frost Proof 3/4 FSAE x 3/4" ID 防冻纳子 3/4 FSAEx3/4" ID		
Drawing No. 图纸编号	M040202417	REV 版次	B
Material Master No. 物料编号	040202417	Drawing Size 图幅	A4
Material 材质	HPb59-1	Sheet Number 页码	1/1
Attribute 属性	3/4 FSAEx3/4"ID	Third Angle Projection 第三视角	

Linear Dimensions 线性尺寸	0 Decimal Place 整数	1 Decimal Place 1位小数	2 Decimal Place 2位小数	Angular Dimensions 角度尺寸	0 Decimal Place 整数	1 Decimal Place 1位小数	Ra 1.6	Estimated Weight 预估重量	163.95g	Scale 比例	1:1	Unit 绘图单位	mm
	± 1.0	± 0.2	± 0.05		$\pm 2^\circ$	$\pm 0.5^\circ$							
Tolerance Unless Stated Otherwise 未注尺寸公差													

Approved_by 批准	Julian Parker	2019/03/20	
Checked_by 审核	Leo Wu	2019/03/20	
Drawn_by 绘图	Li.Dongsen	2019/03/20	