

HGI Part No.	29/06/2018 JTP APPROVED DOCUMENT
999-655-0404HT	

REV. 版本	ENC 工程变更通知	Description 变更描述	Name 变更人	Date 变更日期

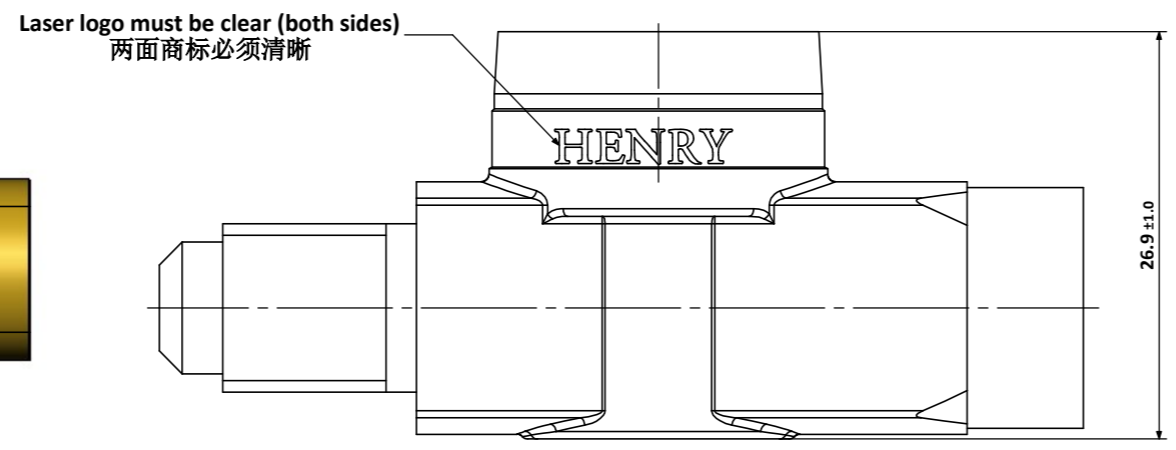

Label Orientation
标签方向
Scale 1.5:1



Laser logo must be clear (both sides)
两面商标必须清晰

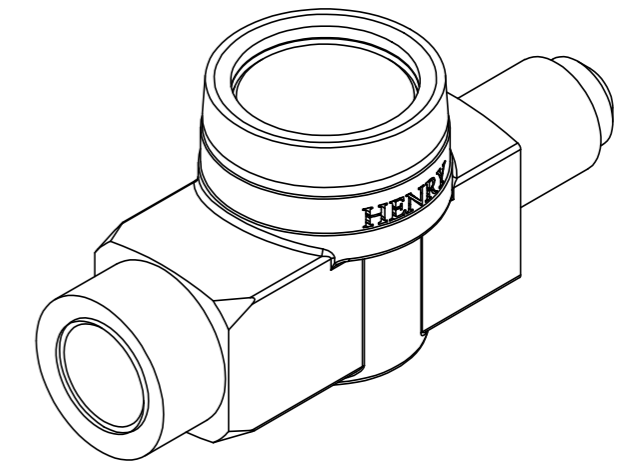

ISO 1.5:1

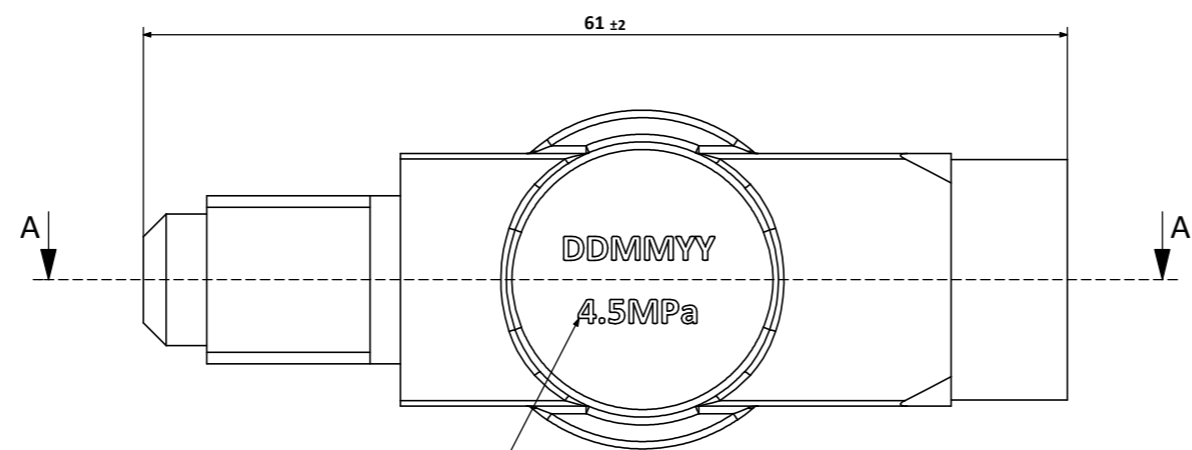

Laser mark date of manufacture DDMMYY and pressure rating to forging base
在阀体底面上激光标记生产日期和承受压力

- Technical Requirements:**
技术要求:
1. Use roll form to crimp the glass, 用旋铆缩口方式来铆合镜片;
 2. No cracks or dirt on roll form surface, 铆合面不得有裂纹或夹杂等缺陷;
 3. Safe working pressure 4.5 MPa, 安全工作压力为4.5 MPa;
 4. Burst pressure 22.5 MPa, 爆破压力为22.5 MPa;
 5. Operating temperature range of -50°C to +85°C, 操作温度范围为-50°C到+85°C;
 6. The bottom of the body should be clear, laser marked before production, 装配前应在本体底部激光打标识, 并且要清晰;
 7. Manufactured to UL207. 符合UL207标准。

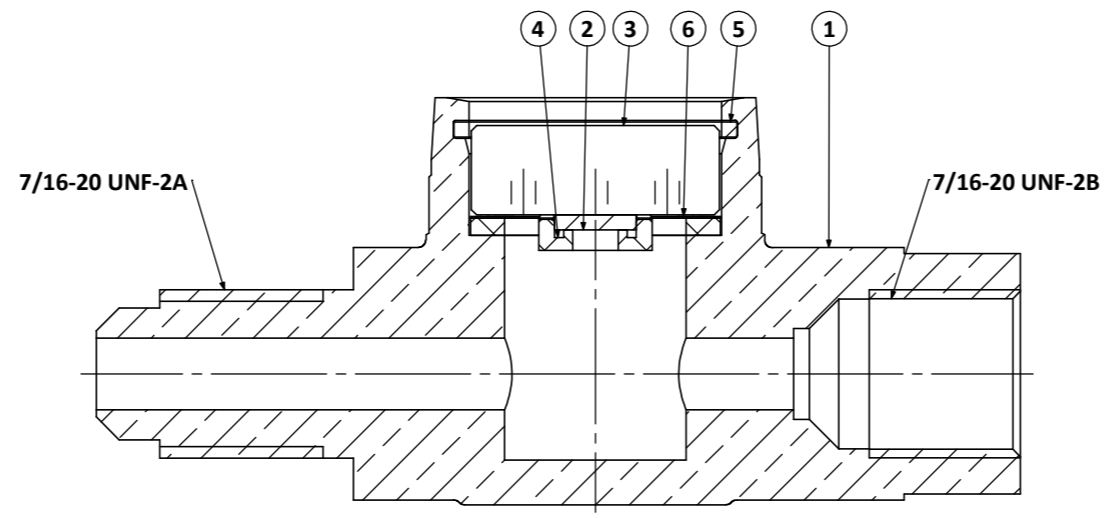

Section A-A

Item 序号	WMC MMN 孟氏物料编号	HGI Part No. 亨利物料编号	Description 描述	Material 材质	QTY 数量
6	030605006	PL-110	Indicator Label 视镜镜标签	Paper	1
5	030309005	932-SG-187	Sight Glass Gasket Ø18.7mm 视镜镜密封圈	Teflon	1
4	030301002	925-083	Mounting Disc 支架	PA66	1
3	030509036	899-SG-164	Ø16.4mm Glass 视镜镜片	Soda Glass Toughened	1
2	030509191	899-SG-54	Ø5.4mm Indicator Paper, T=1.0mm 视镜镜试纸	Paper	1
1	030202136	743-655-0404MF	Sight Glass Body 1/4 MSAE x 1/4 FSAE 视镜镜阀体 1/4 MSAE x 1/4 FSAE	CW617N	1

Description 产品名称		Sight Glass Assembly 1/4 MSAE x 1/4 FSAE 视镜镜组件 1/4 MSAE x 1/4 FSAE		
Drawing No. 图纸编号	M030509418	REV 版次	A	
Material Master No. 物料编号	030509418	Drawing Size 图幅	A3	
Material 材质	Refer Table	Sheet Number 页码	1/1	
Attribute 属性	7/16-20 UNF-2A x 7/16-20 UNF-2B	Third Angle Projection 第三视角		

Dimensions inside an oval are critical dimensions
椭圆内尺寸为关键尺寸

Linear Dimensions 线性尺寸 (mm)	0 Decimal Place 整数	1 Decimal Place 1位小数	2 Decimal Place 2位小数	Angular Dimensions 角度尺寸	0 Decimal Place 整数	1 Decimal Place 1位小数	Ra 1.6	Estimated Weight 预估重量	100.7g	Scale 比例	2:1	Unit 绘图单位	mm
	±1.0	±0.2	±0.05		±2°	±0.5°							
Tolerance Unless Stated Otherwise 未注尺寸公差													

Approved_by 批准	Julian Parker	6/29/2018
Checked_by 审核	Leo Wu	6/28/2018
Drawn_by 绘图	Nancy Huang	6/27/2018

