

HGI Part No.  
670-2222 -customer

17/07/2018 HENRY  
JTP  
APPROVED DOCUMENT

REV. 版本	ENC 工程变更通知	Description 变更描述	Name 变更人	Date 变更日期

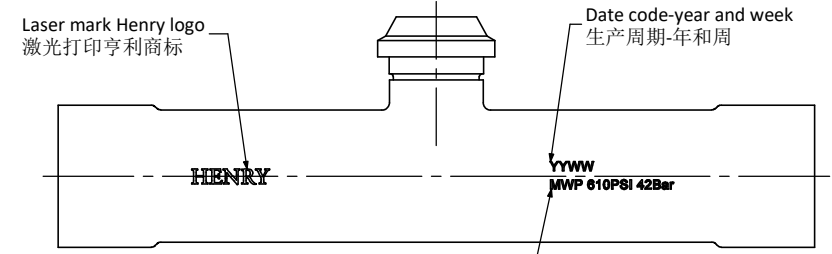
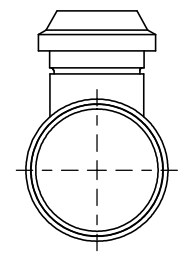
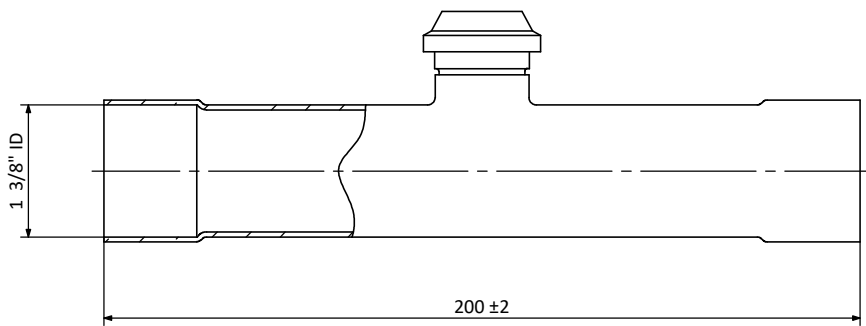

Max Working Pressure: 610PSI (42Bar)  
最大工作压力: 610PSI (42Bar)

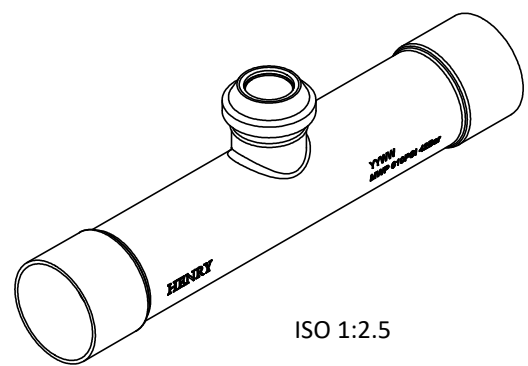

ISO 1:2.5

- Technical Requirements:**  
技术要求:
1. Safe working pressure 4.2MPa;  
安全工作压力为4.2MPa;
  2. Leak test pressure 6MPa;  
泄漏测试压力为6MPa;
  3. Burst pressure 12.6MPa;  
爆破压力为12.6MPa;
  4. Operating temperature range of -50°C to +85°C;  
操作温度范围为-50°C ~ +85°C;
  5. Manufacture to AS/NZS 5149.2.  
制造标准为 AS/NZS 5149.2.

Description 产品名称		Hermetic Sight Glass 1 3/8" 视镜 1 3/8"	
Drawing No. 图纸编号	M030509427	REV 版次	A
Material Master No. 物料编号	030509427	Drawing Size 图幅	A4
Material 材质	N/A	Sheet Number 页码	1/1
Attribute 属性	1 3/8"	Third Angle Projection 第三视角	

Linear Dimensions 线性尺寸	0 Decimal Place 整数	1 Decimal Place 1位小数	2 Decimal Place 2位小数	Angular Dimensions 角度尺寸	0 Decimal Place 整数	1 Decimal Place 1位小数	Ra 1.6	Estimated Weight 预估重量	N/A
	±1.0	±0.2	±0.05		±2°	±0.5°		Scale 比例	1:2
Tolerance Unless Stated Otherwise 未注尺寸公差								Unit 绘图单位	mm

