

HGI Part No.		11/05/2022 HENRY JTP APPROVED DOCUMENT		<input checked="" type="checkbox"/> PED 2014/68/EU <input checked="" type="checkbox"/> AS2971.2 <input checked="" type="checkbox"/> UL207		REV. 版本	ECN 工程变更通知	Description 变更描述	Name 变更人	Date 变更日期	
S-1904-customer				<input type="checkbox"/> CAT I <input type="checkbox"/> CAT II <input checked="" type="checkbox"/> CAT III		B	ECN-HT21054	Add Pre-charge Volume 680 mL/ 23 fl.oz. Add the Lifting Lug	Qiu Leixin	2021/12/29	
		Volume Ltrs	Shell ID mm	Design Pressure MPa	Leak Test Pressure MPa	Proof Test Pressure MPa	C	ECN-HT22008	Cancel stamp heat number	Angel Zhang	2022/5/7
		27	Ø292.1	3.1	3.1	4.65					

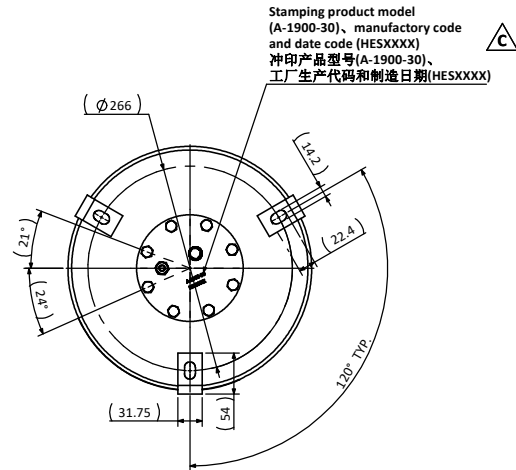

Stamping manufacturing code and date code(HESXXXX)
冲印工厂代码和制造日期(HESXXXX)

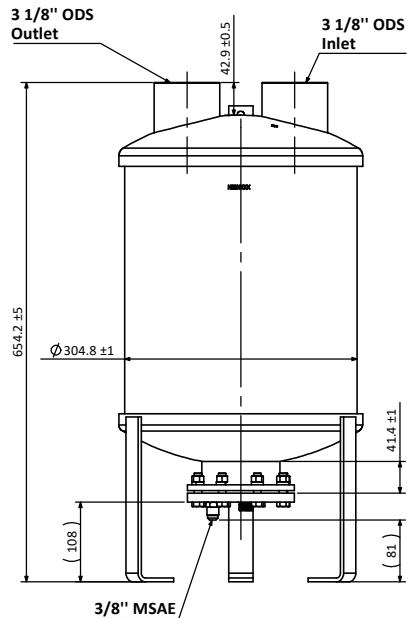
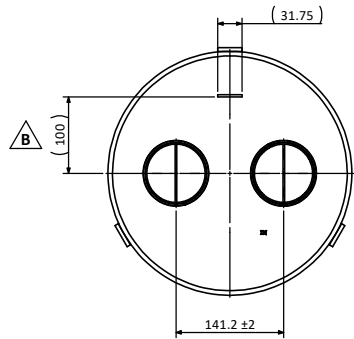
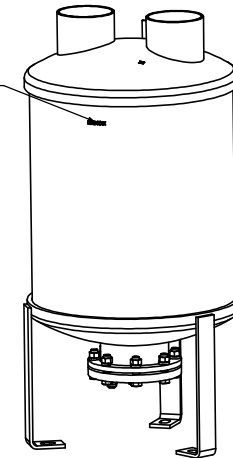

Stamping product model (A-1900-30), manufacturing code and date code (HESXXXX)
冲印产品型号(A-1900-30)、工厂生产代码和制造日期(HESXXXX)

Technical Requirements:
技术要求

1. Allowable operating temperature -10°C to +130°C;
工作温度-10°C到+130°C;
2. Pre-charge Volume 680 mL/ 23 fl.oz.;
预充油体积: 680 mL/ 23 fl.oz.;
3. Powder coating: Henry Blue, RAL 5013.
喷涂颜色: 亨利蓝色, RAL 5013.

Description 产品名称	Oil Separator 3 1/8" ODS 油分离器3 1/8" ODS		
Drawing No. 图纸编号	M050505342	REV 版次	C
Material Master No. 物料编号	050505342	Drawing Size 图幅	A3
Material 材质	Refer Table	Sheet Number 页码	1/1
Attribute 属性	3 1/8" ODS	Third Angle Projection 第三视角	

Linear Dimensions 线性尺寸 (mm)	0 Decimal Place 整数	1 Decimal Place 1位小数	2 Decimal Place 2位小数	Angular Dimensions 角度尺寸	0 Decimal Place 整数	1 Decimal Place 1位小数	Ra 1.6 	Estimated Weight 预估重量	N/A	Approved_by 批准	Julian Parker	2021/6/24
	±1.0	±0.2	±0.05		±2°	±0.5°						
Tolerance Unless Stated Otherwise 未注尺寸公差												
								Unit 绘图单位	mm	Drawn_by 绘图	Angel Zhang	2021/6/24

