

HGI Part No. S-5302-GY-customer	24/07/2020 HENRY JTP APPROVED DOCUMENT	<input checked="" type="checkbox"/> PED 2014/68/EU	<input checked="" type="checkbox"/> AS2971.2	<input checked="" type="checkbox"/> UL207	REV. 版本	ECN 工程变更通知	Description 变更描述	Name 变更人	Date 变更日期
		<input type="checkbox"/> CAT I	<input type="checkbox"/> CAT II	<input checked="" type="checkbox"/> CAT III					
Volume Ltrs	Shell ID mm	Design Pressure MPa	Leak Test Pressure MPa	Proof Test Pressure MPa	Min Burst Test Pressure MPa				
16.85	Ø193.5	3.1	3.1	4.65	15.5				

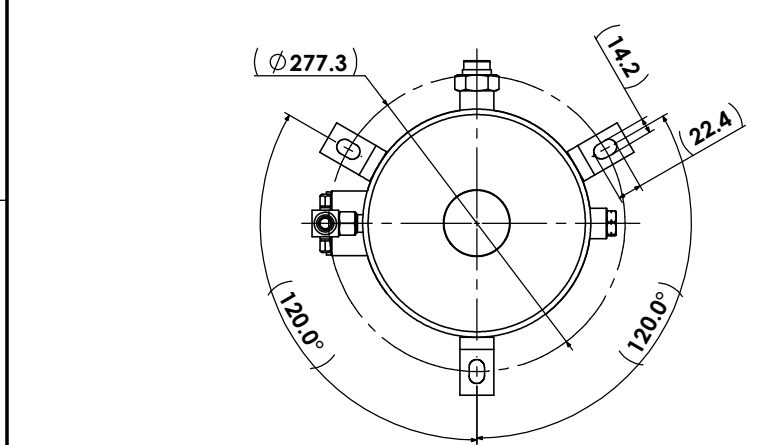
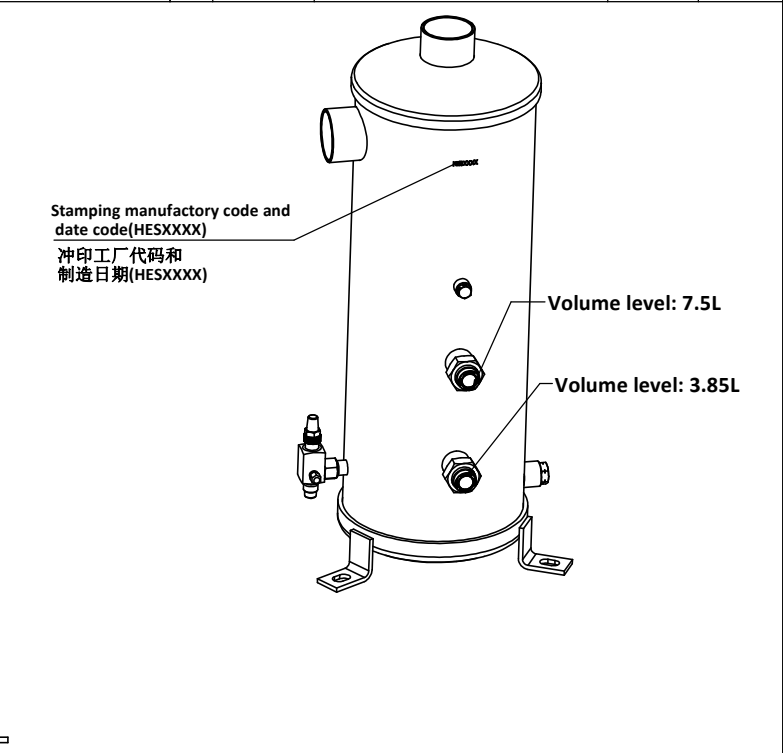
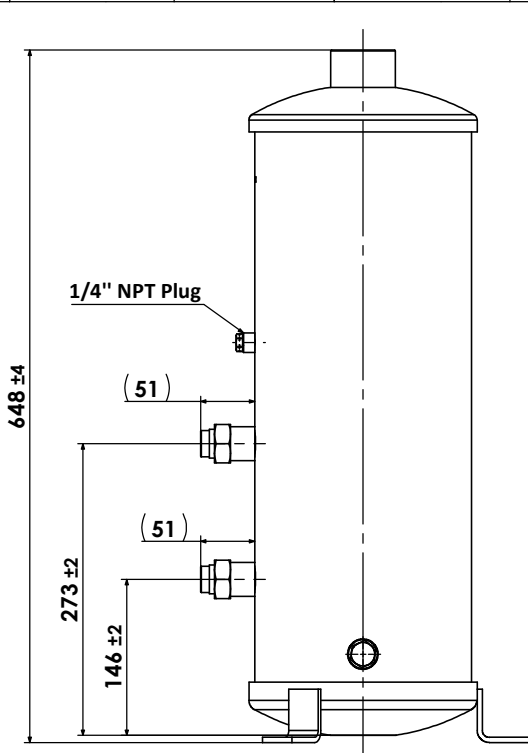
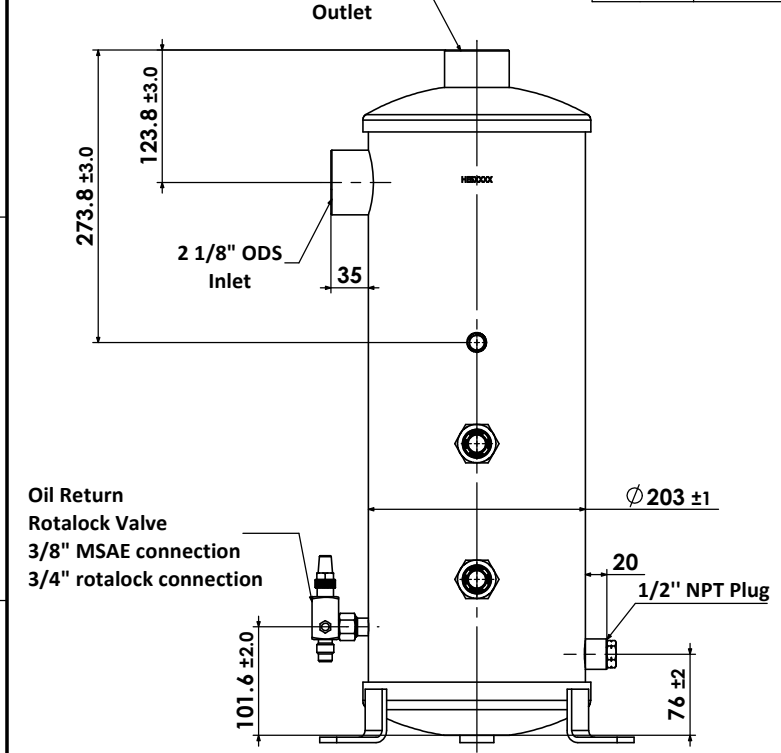

- Technical Requirements:  
技术要求
1. Allowable operating temperature -10°C to +130°C;  
工作温度-10°C到+130°C;
  2. Powder coating: Gray RAL7035;  
喷涂颜色: 灰色 RAL 7035 ;
  3. Rotalock Valve and Gasket will be packed with product independently.  
阀和垫圈随产品单独包装。

Description 产品名称	Helical Oil Separator Reservoir 2 1/8" ODS 螺旋油分离储液器 2 1/8" ODS		
Drawing No. 图纸编号	M050505281	REV 版次	A
Material Master No. 物料编号	050505281	Drawing Size 图幅	A3
Material 材质	Refer Table	Sheet Number 页码	1/1
Attribute 属性	2 1/8" ODS	Third Angle Projection 第三视角	

Dimensions inside an oval are critical dimensions 椭圆内尺寸为关键尺寸	Linear Dimensions 线性尺寸 (mm)	0 Decimal Place 整数 ±1.0	1 Decimal Place 1位小数 ±0.2	2 Decimal Place 2位小数 ±0.05	Angular Dimensions 角度尺寸	0 Decimal Place 整数 ±2°	1 Decimal Place 1位小数 ±0.5°	Ra 1.6	Estimated Weight 预估重量	N/A	Scale 比例	1:5	Unit 绘图单位	mm
	Tolerance Unless Stated Otherwise 未注尺寸公差													

Approved_by 批准	Julian Parker	2020/7/20	
Checked_by 审核	Leo Wu	2020/7/20	
Drawn_by 绘图	Angel Zhang	2020/7/20	