

HGI Part No. S-5590-customer		30/05/2022 HENRY JTP APPROVED DOCUMENT		<input checked="" type="checkbox"/> PED 2014/68/EU <input type="checkbox"/> CAT I <input checked="" type="checkbox"/> CAT II <input checked="" type="checkbox"/> B <input checked="" type="checkbox"/> AS2971.2 <input checked="" type="checkbox"/> UL207		REV. 版本	ECN 工程变更通知	Description 变更描述	Name 变更人	Date 变更日期
				Volume Ltrs		B		CAT II was CAT I, Pre-charge volume 500 ml/ 17 fl.oz. WAS 600 ml/ 21 fl.oz.	Angel Zhang	2022/5/20
				Shell ID mm						
				Design Pressure MPa						
				Leak Test Pressure MPa						
				Proof Test Pressure MPa						
				Min Burst Test Pressure MPa						

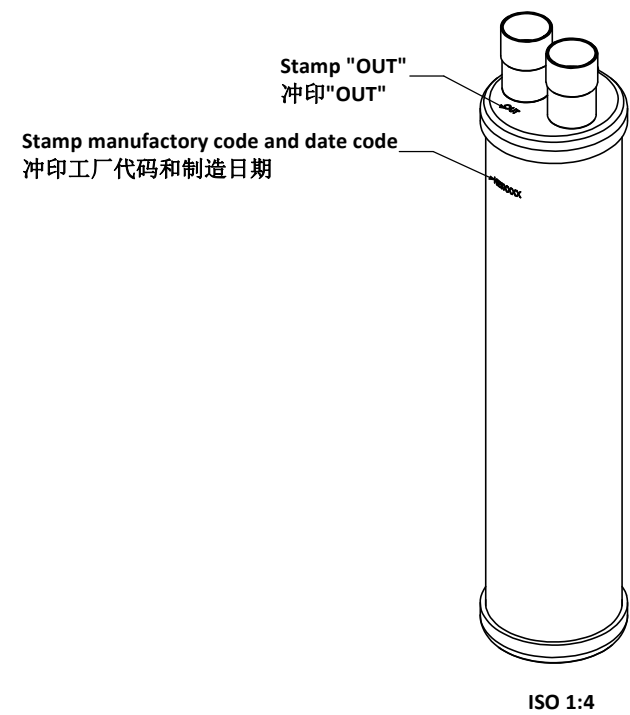
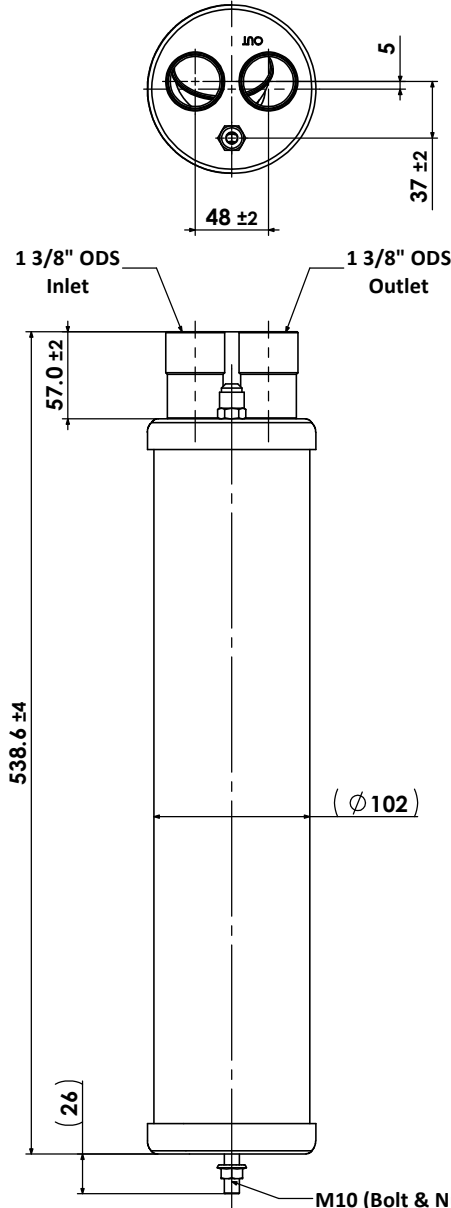

- Technical Requirements:**
技术要求
1. Pre-charge Volume 500 ml/ 17 fl.oz.;
预充油体积: 500 ml/ 17 fl.oz.; B
 2. Allowable operating temperature -10°C to +130°C;
工作温度-10°C到+130°C;
 3. Powder coating: Henry Blue RAL 5013.
喷涂颜色: 亨利蓝RAL 5013。

Description 产品名称		Oil Separator 油分离器	
Drawing No. 图纸编号	M050509932	REV 版次	B
Material Master No. 物料编号	050509932	Drawing Size 图幅	A3
Material 材质	N/A	Sheet Number 页码	1/1
Attribute 属性	1 3/8" ODS	Third Angle Projection 第三视角	
Approved_by 批准	Julian Parker	2021/10/14	
Checked_by 审核	Leo Wu	2021/10/14	
Drawn_by 绘图	Nancy Huang	2018/11/8	

Linear Dimensions 线性尺寸 (mm)	0 Decimal Place 整数	1 Decimal Place 1位小数	2 Decimal Place 2位小数	Angular Dimensions 角度尺寸	0 Decimal Place 整数	1 Decimal Place 1位小数	Ra 1.6	Estimated Weight 预估重量	N/A	Scale 比例	1:3.5	Unit 绘图单位	mm
	±1.0	±0.2	±0.05		±2°	±0.5°							
Tolerance Unless Stated Otherwise 未注尺寸公差													