

HGI Part No. S-5688-customer	01/06/2022 HENRY JTP APPROVED DOCUMENT	<input checked="" type="checkbox"/> PED 2014/68/EU <input checked="" type="checkbox"/> AS2971.2 <input checked="" type="checkbox"/> UL207				REV. 版本	ECN 工程变更通知	Description 变更描述	Name 变更人	Date 变更日期	
		<input type="checkbox"/> CAT I <input checked="" type="checkbox"/> CAT II <input checked="" type="checkbox"/> B	Volume Ltrs	Shell ID mm	Design Pressure MPa	Leak Test Pressure MPa	Proof Test Pressure MPa	Min Burst Test Pressure MPa	B ECN-HT21017	CAT II was CAT I	Qiu Leixin
		5.4	Ø145.4	3.1	3.1	4.43	15.5	C ECN-HT21047	Pre-charge Volume 1050 mL/ 35.5 oz. WAS 860mL/ 30 oz.	Angel Zhang	2022/5/20

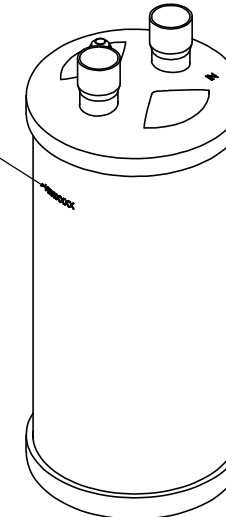
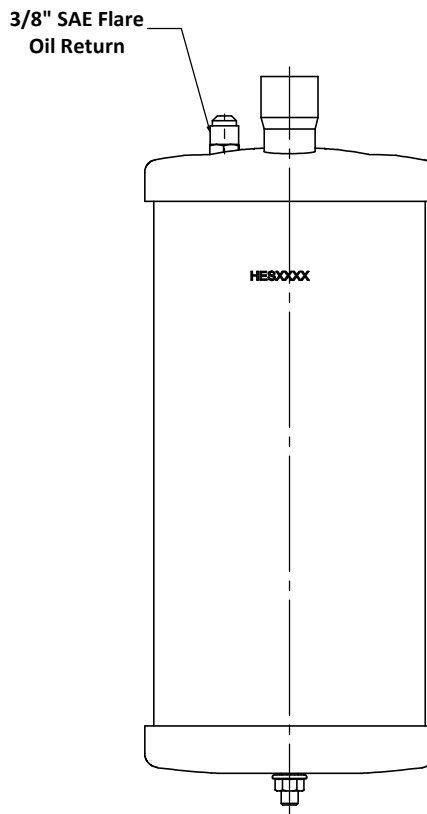
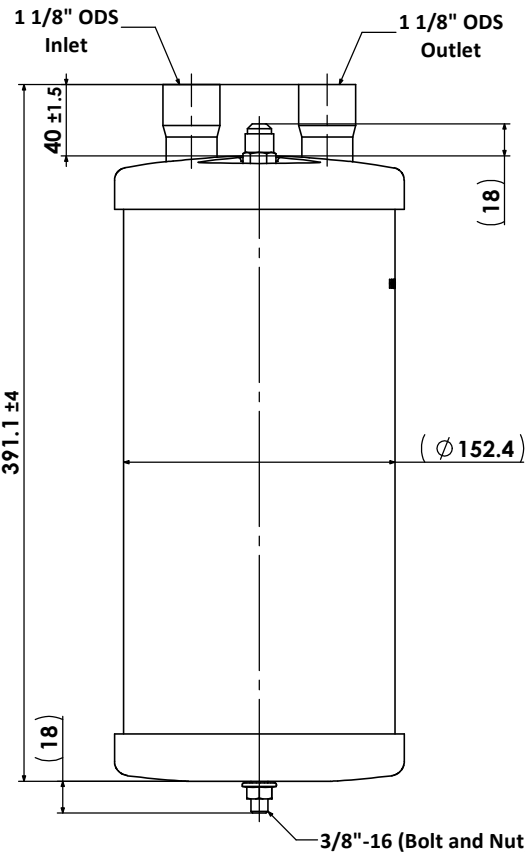
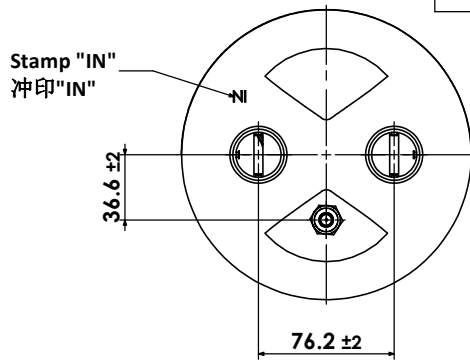

Stamp manufactory code and date code
冲印工厂代码和制造日期

Technical Requirements:
技术要求

1. Pre-charge Volume 1050 mL/ 35.5 oz.;
预充油体积: 1050 mL/ 35.5 oz.; C
2. Allowable operating temperature -10°C to +130°C;
工作温度 -10°C到+130°C;
3. Powder coating: Henry Blue RAL 5013.
喷涂颜色: 亨利蓝 RAL 5013 .

Description 产品名称		Oil Separator 1 1/8" ODS 油分离器 1 1/8" ODS		
Drawing No. 图纸编号	M050505022	REV 版次	C	
Material Master No. 物料编号	050505022	Drawing Size 图幅	A3	
Material 材质	N/A	Sheet Number 页码	1/1	
Attribute 属性	1 1/8" ODS	Third Angle Projection 第三视角	<input checked="" type="checkbox"/>	
Approved_by 批准	Julian Parker	2021/10/15		
Checked_by 审核	Leo Wu	2021/10/15		
Drawn_by 绘图	Nancy Huang	2019/3/14		

Linear Dimensions 线性尺寸 (mm)	0 Decimal Place 整数	1 Decimal Place 1位小数	2 Decimal Place 2位小数	Angular Dimensions 角度尺寸	0 Decimal Place 整数	1 Decimal Place 1位小数	Ra 1.6	Estimated Weight 预估重量	N/A	Scale 比例	1:3	Unit 绘图单位	mm
	±1.0	±0.2	±0.05		±2°	±0.5°							
Tolerance Unless Stated Otherwise 未注尺寸公差													