

HGI Part No.	21/08/2024 HENRY JTP APPROVED DOCUMENT
S-810-CM	

REV. 版本	ECN 工程变更通知	Description 变更描述	Name 变更人	Date 变更日期

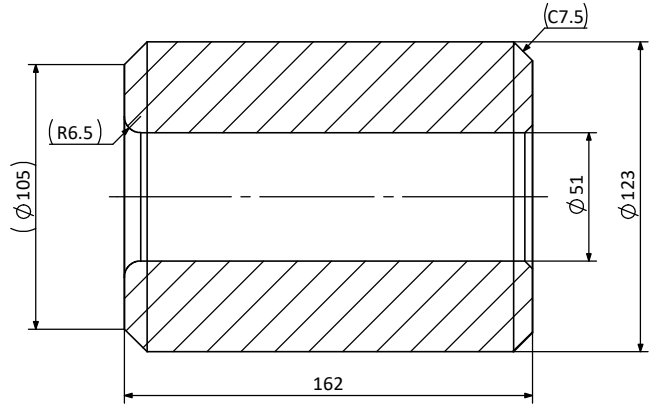
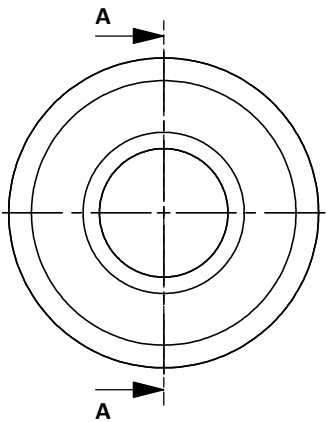

Section A-A

Technical Requirements:

技术要求

- The drier core should be sealed by silver protective bag;
将滤芯用银色保护袋真空密封;
- The drier core and gasket 050309001 should be packed into the box;
将滤芯和垫片050309001装入内盒包装;
- The supplier should stick the product label on the top of the box;
供应商需在盒顶端表面粘贴产品标签;
- Unspecified geometric tolerance according to ISO 2768-K.
未注形位公差依照ISO 2768-K。

Description 产品名称	Drier Core S-810-CM 分子筛 S-810-CM		
Drawing No. 图纸编号	M050509001	REV 版次	A
Material Master No. 物料编号	050509001	Drawing Size 图幅	A4
Material 材质	100%MS	Sheet Number 页码	1/1
Attribute 属性	N/A	Third Angle Projection 第三视角	

Linear Dimensions 线性尺寸	0 Decimal Place 整数	1 Decimal Place 1位小数	2 Decimal Place 2位小数	Angular Dimensions 角度尺寸	0 Decimal Place 整数	1 Decimal Place 1位小数	Ra 1.6	Estimated Weight 预估重量	N/A
	±1.0	±0.2	±0.05		±2°	±0.5°		Scale 比例	1:3
Tolerance Unless Stated Otherwise 未注尺寸公差								Unit 绘图单位	mm

Approved_by 批准	Julian Parker	2024/8/12
Checked_by 审核	Leo Wu	2024/8/12
Drawn_by 绘图	Qiu Leixin	2024/8/12



A

B

C

D