

HGI Part No. S-7044-customer	04/03/2025 HENRY JTP APPROVED DOCUMENT	<input checked="" type="checkbox"/> PED 2014/68/EU <input checked="" type="checkbox"/> AS2971.2 <input checked="" type="checkbox"/> UL207				REV. 版本	ECN 工程变更通知	Description 变更描述	Name 变更人	Date 变更日期	
		<input checked="" type="checkbox"/> CAT I <input type="checkbox"/> CAT II				B	ECN-HT19018	S-7044-customer was SA-7044K-customer. Add 1/4" NPT plug.	Nancy Huang	2019/3/28	
		Volume Ltrs	Shell ID mm	Design Pressure MPa	Leak Test Pressure MPa	Proof Test Pressure MPa	C	ECN-HT20010	Add UL207; Add CAT I; 15.5 was 13.7	Zhou Lei	2020/03/27
		1.6	∅97	3.1	3.1	4.43	△ C	ECN-HT25002	Design temperature updated from -30°C~50°C to -30°C~80°C	Qiu Leixin	2025/02/19

Stamp "IN"  
冲印"IN"

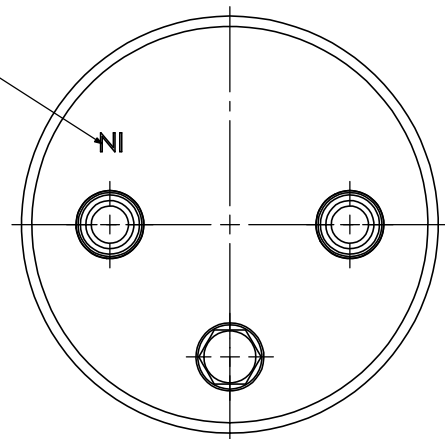

1/2" ODS Copper Inlet      63.5 ±2      1/2" ODS Copper Outlet

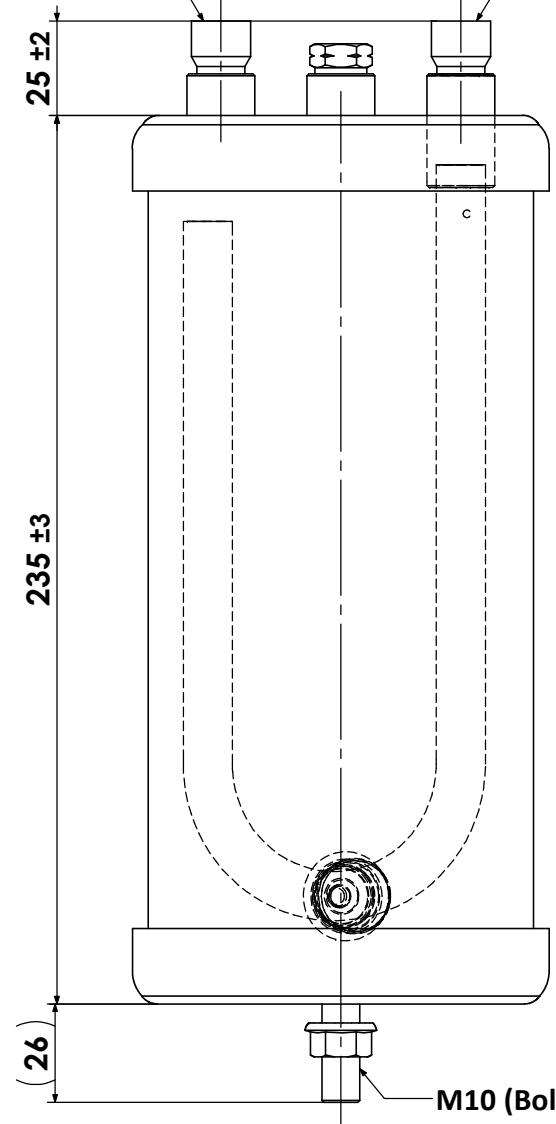

M10 (Bolt & Nut)

1/4" NPT plug

△ B

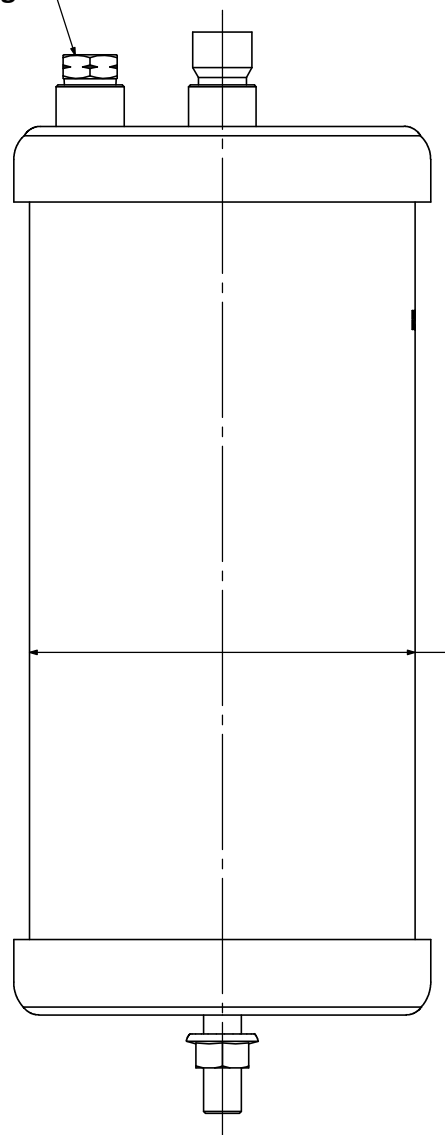

Stamp factory code and date code  
冲印工厂代码和制造日期

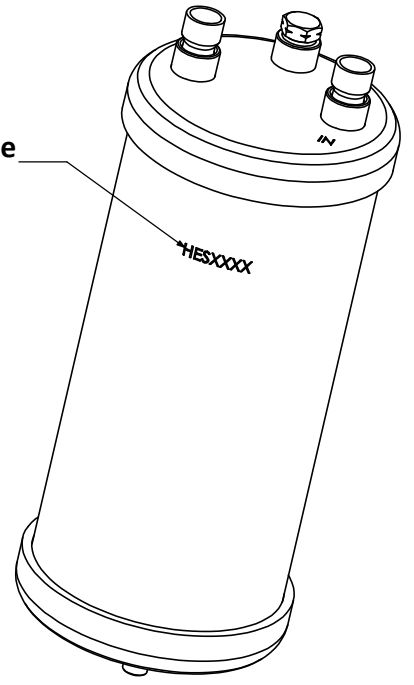

**Technical Requirements:**  
技术要求

1. Allowable operating temperature -30°C to +80°C;  
工作温度-30°C到+80°C; △ D
2. Powder coating: Henry Blue RAL 5013.  
喷涂颜色: 亨利蓝RAL 5013.

Description 产品名称	Suction Accumulator 1.6L 气液分离器 1.6L		
Drawing No. 图纸编号	M050509945	REV 版次	D
Material Master No. 物料编号	050509945	Drawing Size 图幅	A3
Material 材质	N/A	Sheet Number 页码	1/1
Attribute 属性	1/2" ODS	Third Angle Projection 第三视角	

Linear Dimensions 线性尺寸 (mm)	0 Decimal Place 整数	1 Decimal Place 1位小数	2 Decimal Place 2位小数	Angular Dimensions 角度尺寸	0 Decimal Place 整数	1 Decimal Place 1位小数	Ra 1.6 	Estimated Weight 预估重量	N/A	Approved_by 批准	Julian Parker	2025/02/19
	±1.0	±0.2	±0.05		±2°	±0.5°		Scale 比例	1:2	Checked_by 审核	Leo Wu	2025/02/19
Tolerance Unless Stated Otherwise 未注尺寸公差								Unit 绘图单位	mm	Drawn_by 绘图	Nancy Huang	2018/10/22

