

HGI Part No. S-7053-customer	03/03/2025 JTP APPROVED DOCUMENT	<input checked="" type="checkbox"/> PED 2014/68/EU <input checked="" type="checkbox"/> AS2971.2 <input checked="" type="checkbox"/> UL207				REV. 版本	ECN 工程变更通知	Description 变更描述	Name 变更人	Date 变更日期	
		<input type="checkbox"/> CAT I <input checked="" type="checkbox"/> CAT II	Volume Ltrs	Shell ID mm	Design Pressure MPa	Leak Test Pressure MPa	Proof Test Pressure MPa	Min Burst Test Pressure MPa	B	ECN-HT25002	Design temperature updated from -30°C~50°C to -30°C~80°C
		4.8	∅121	3.1	3.1	4.43					

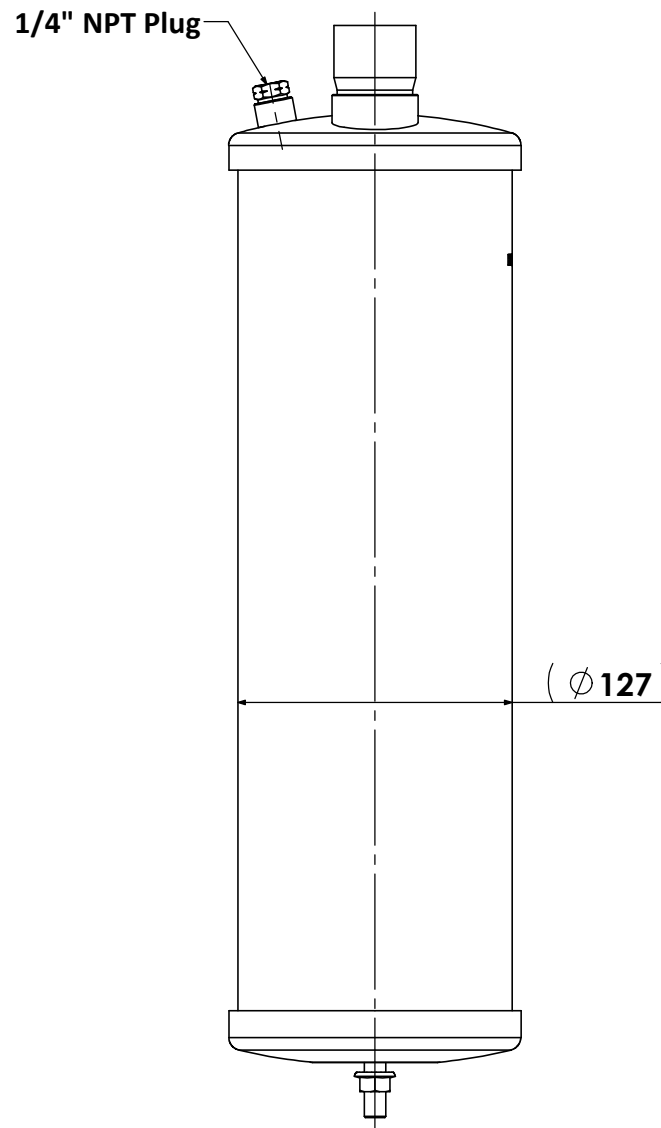

Stamp "IN"
冲印"IN"

Stamp factory code and date code
冲印工厂代码和制造日期

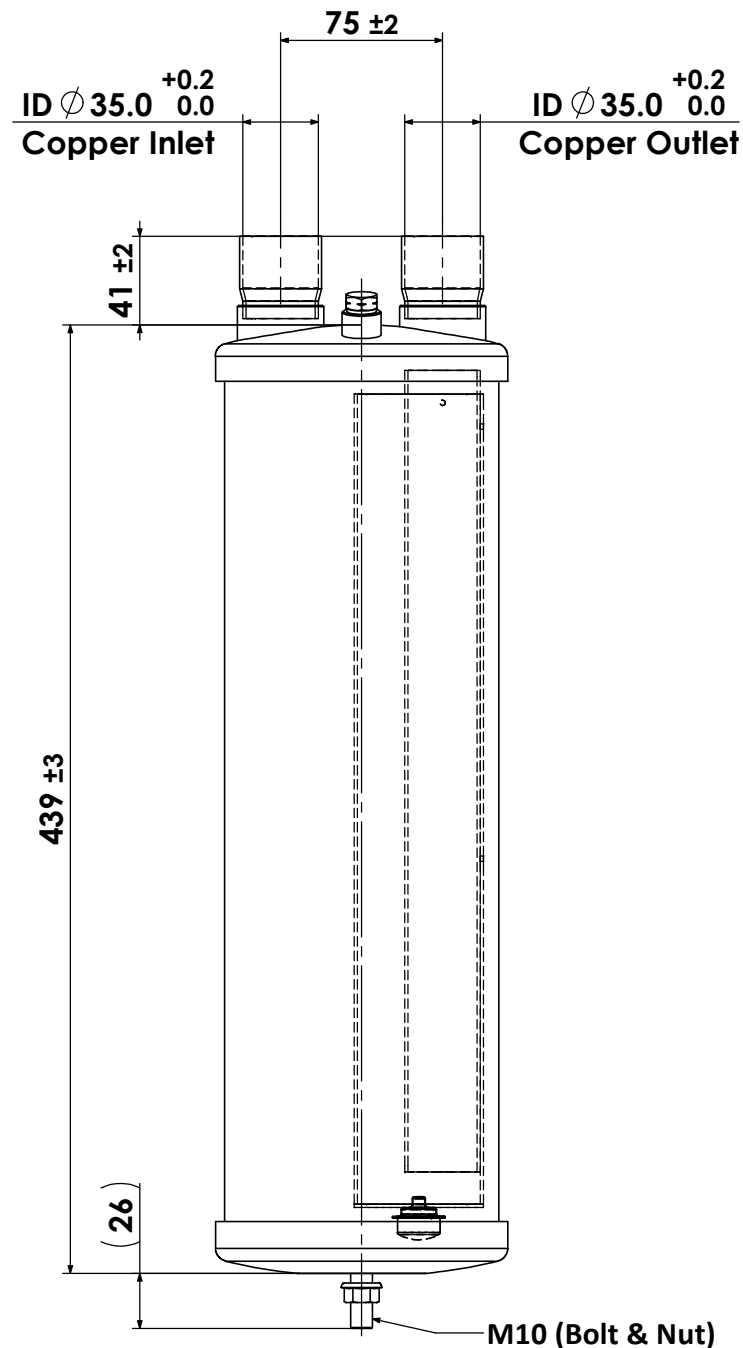
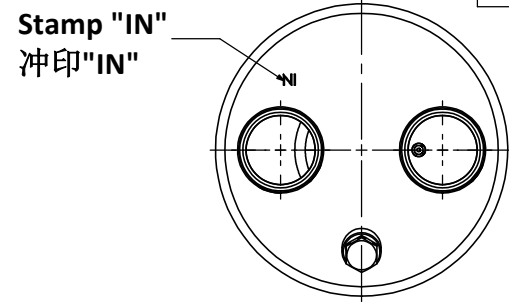
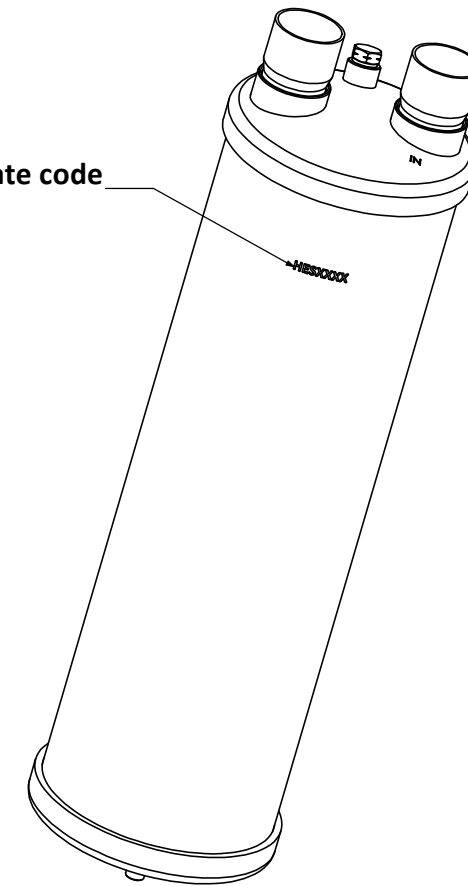

ISO 1:4

Technical Requirements:

技术要求

1. Allowable operating temperature -30°C to +80°C; B
工作温度-30°C到+80°C;
2. Powder coating: Henry Blue RAL 5013.
喷涂颜色: 亨利蓝RAL 5013.

Description 产品名称	Suction Accumulator 4.8L 气液分离器 4.8L		
Drawing No. 图纸编号	M050505260	REV 版次	B
Material Master No. 物料编号	050505260	Drawing Size 图幅	A3
Material 材质	N/A	Sheet Number 页码	1/1
Attribute 属性	1 3/8" ODS	Third Angle Projection 第三视角	

Linear Dimensions 线性尺寸 (mm)	0 Decimal Place 整数	1 Decimal Place 1位小数	2 Decimal Place 2位小数	Angular Dimensions 角度尺寸	0 Decimal Place 整数	1 Decimal Place 1位小数	Ra 1.6	Estimated Weight 预估重量	N/A	Approved_by 批准	Julian Parker	2025/02/19
	±1.0	±0.2	±0.05		±2°	±0.5°		Scale 比例	1:3.5	Checked_by 审核	Leo Wu	2025/02/19
Tolerance Unless Stated Otherwise 未注尺寸公差								Unit 绘图单位	mm	Drawn_by 绘图	Nancy Huang	2020/4/7

HENRY