

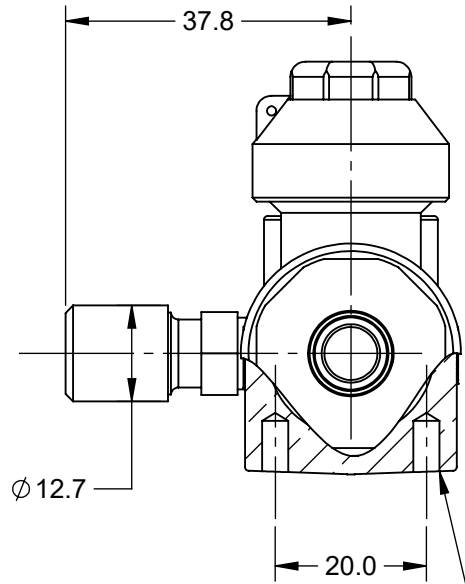

GENERAL TOLERANCES	ALL DIMENSIONS IN mm
NO DECIMAL PLACES = ±1.5	ANGULAR = ±2°
ONE DECIMAL PLACE = ±1.0	ALL UNSPECIFIED
TWO DECIMAL PLACES = ±0.5	ANGLES SHALL BE 45°

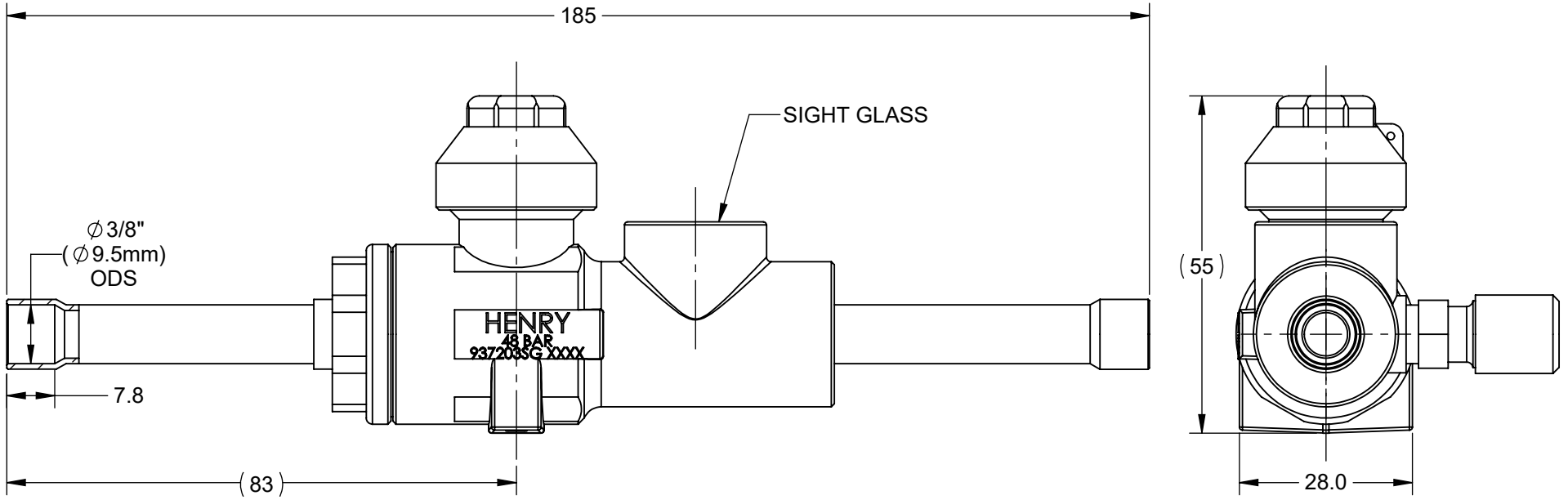

- NOTES:
1. MAXIMUM WORKING PRESSURE: 60 BARG
 2. OPERATING TEMPERATURE: -40°C to +120°C
 3. CO₂, HCFC & HFC COMPATIBLE
 4. BI-DIRECTIONAL FLOW

MOUNTING HOLES 8-36 UNF-2B (2 POSITIONS)

CONNECTION SIZE	MATERIAL	
3/8" ODS		
DESCRIPTION OF EQUIPMENT		
3/8" (9.5mm) ODS Ball Valve, Sight Glass (Schrader)		
PART NUMBER	937203SG	CURRENT ACTIVE REVISION A
SCALE	1:1	
DRAWN	R.Muholland	
DATE	21/09/23	
CUSTOMER DRAWING		DRAWING No. 937203SG-Cust
		REVISION A

