

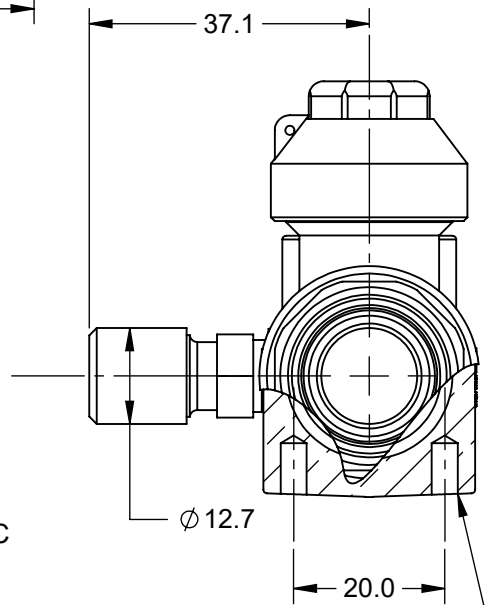

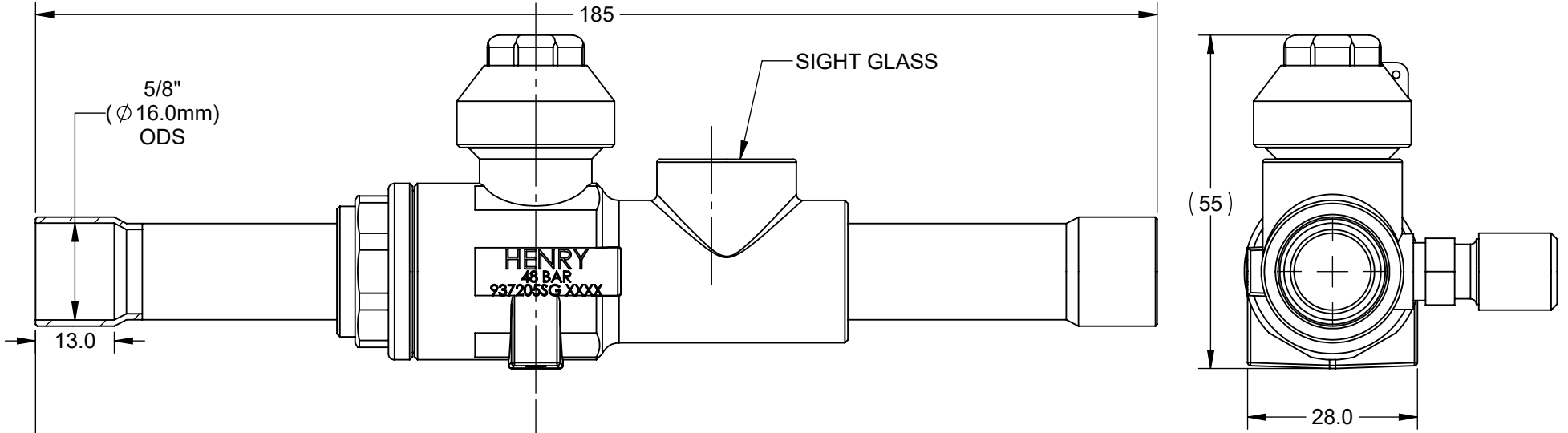

GENERAL TOLERANCES	ALL DIMENSIONS IN mm
NO DECIMAL PLACES = ±1.5	ANGULAR = ±2°
ONE DECIMAL PLACE = ±1.0	ALL UNSPECIFIED
TWO DECIMAL PLACES = ±0.5	ANGLES SHALL BE 45°



NOTES:

1. MAXIMUM WORKING PRESSURE: 60 BARG
2. OPERATING TEMPERATURE: -40°C to +120°C
3. CO₂, HCFC & HFC COMPATIBLE
4. BI-DIRECTIONAL FLOW

MOUNTING HOLES 8-36 UNF-2B (2 POSITIONS)

CONNECTION SIZE	5/8" ODS	MATERIAL	
DESCRIPTION OF EQUIPMENT	5/8" (16.0mm) ODS Ball Valve, Sight Glass (Schrader)		
PART NUMBER	937205SG	CURRENT ACTIVE REVISION	A
SCALE	1:1	 HILLINGTON, GLASGOW, UK	
DRAWN	R.Muholland		
DATE	21/09/23		
CUSTOMER DRAWING	DRAWING No.	937205SG-Cust	REVISION A