

GENERAL TOLERANCES	ALL DIMENSIONS IN mm
NO DECIMAL PLACES = ±1.5	ANGULAR = ±2°
ONE DECIMAL PLACE = ±1.0	ALL UNSPECIFIED
TWO DECIMAL PLACES = ±0.5	ANGLES SHALL BE 45°

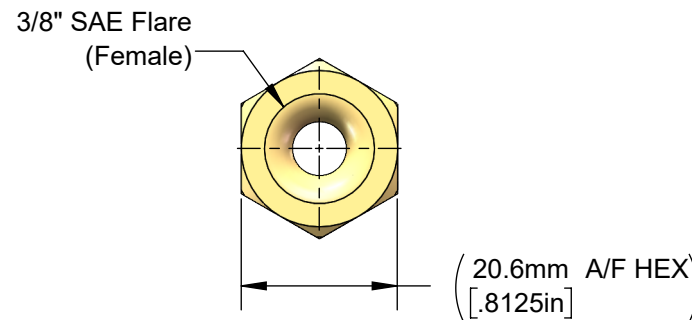
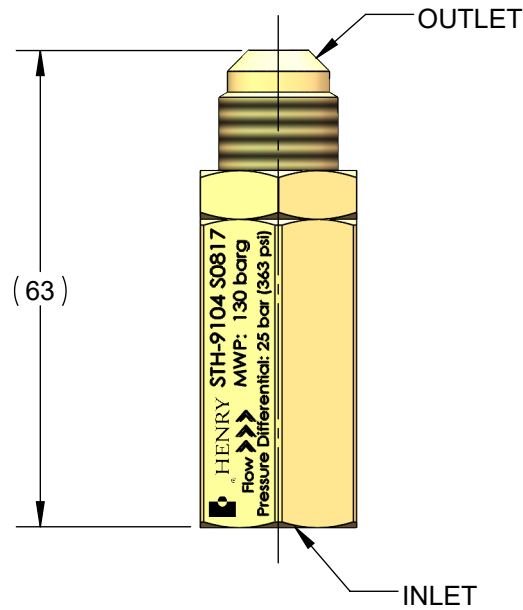
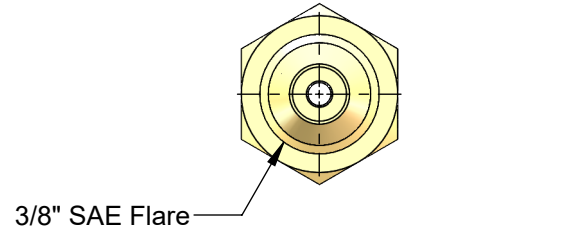

**VALVE PARAMETERS**

Model: STH-9104  
 Inlet Size: 3/8" SAE Flare (Female)  
 Max Working Pressure: 130 barg  
 Temperature Range: -10°C to +150°C  
 Certification: N/A (CE Category; SEP)

**VALVE PRESSURE DIFFERENTIAL OPTIONS**

- 0.35 bar (5 psi)
- 1.4 bar (20 psi)
- 2.4 bar (35 psi)
- 4.5 bar (65 psi)
- 25 bar (363 psi)

CONNECTION SIZE 3/8" SAE Flare	MATERIAL Brass
DESCRIPTION OF EQUIPMENT <b>Pressure Regulating Valve</b>	
PART NUMBER STH-9104	CURRENT ACTIVE REVISION A
SCALE 1:1	 <b>HILLINGTON, GLASGOW, UK</b>
DRAWN J. Gronkowski	
DATE 25/05/17	DRAWING No.
CUSTOMER DRAWING	<b>STH-9104-Cust</b>
	REVISION <b>A</b>