

8 7 6 5 4 3 2 1

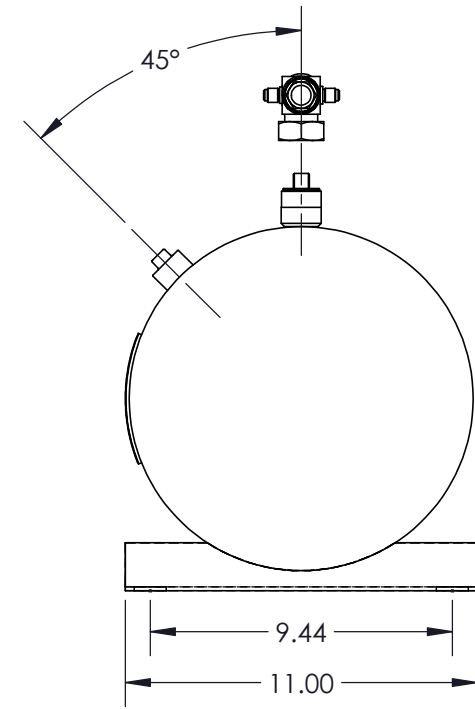
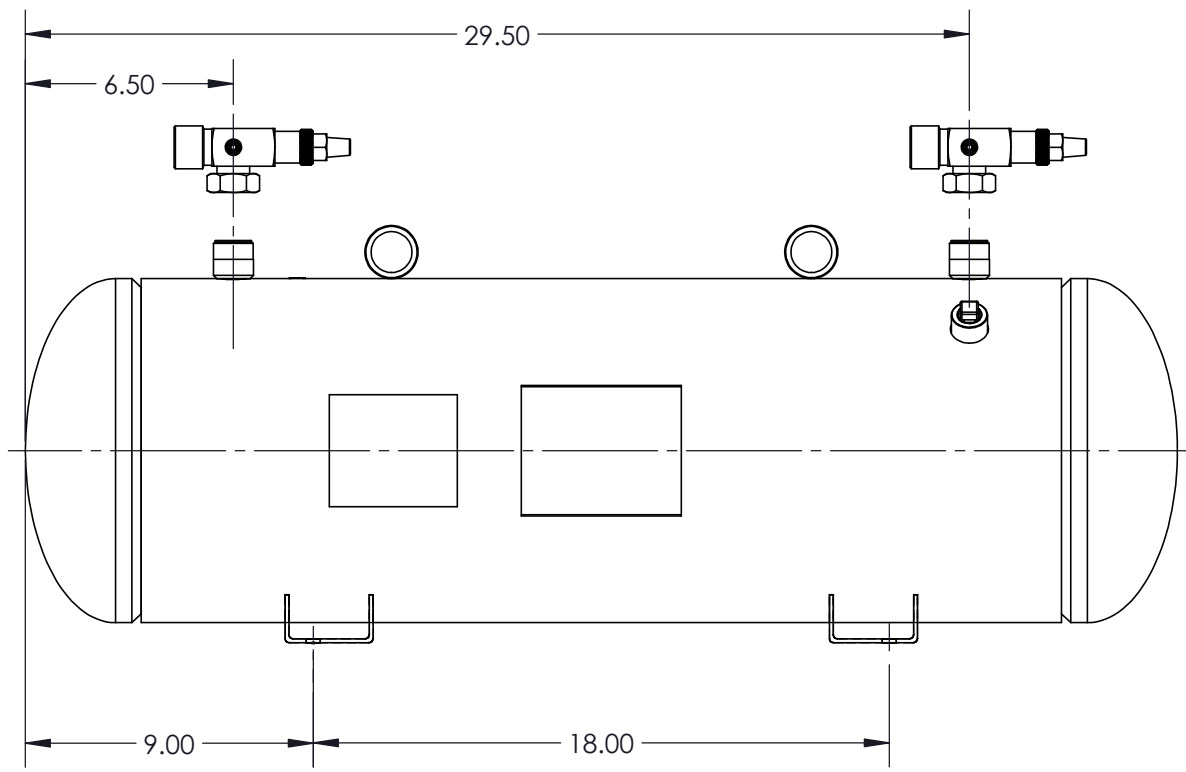
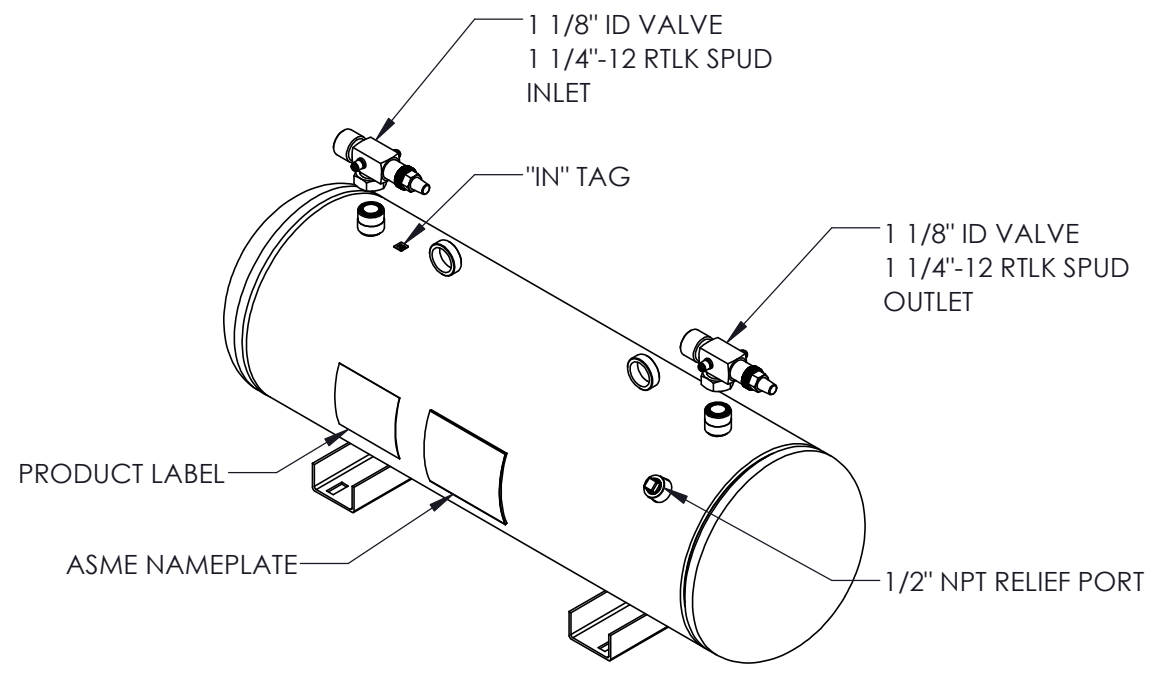
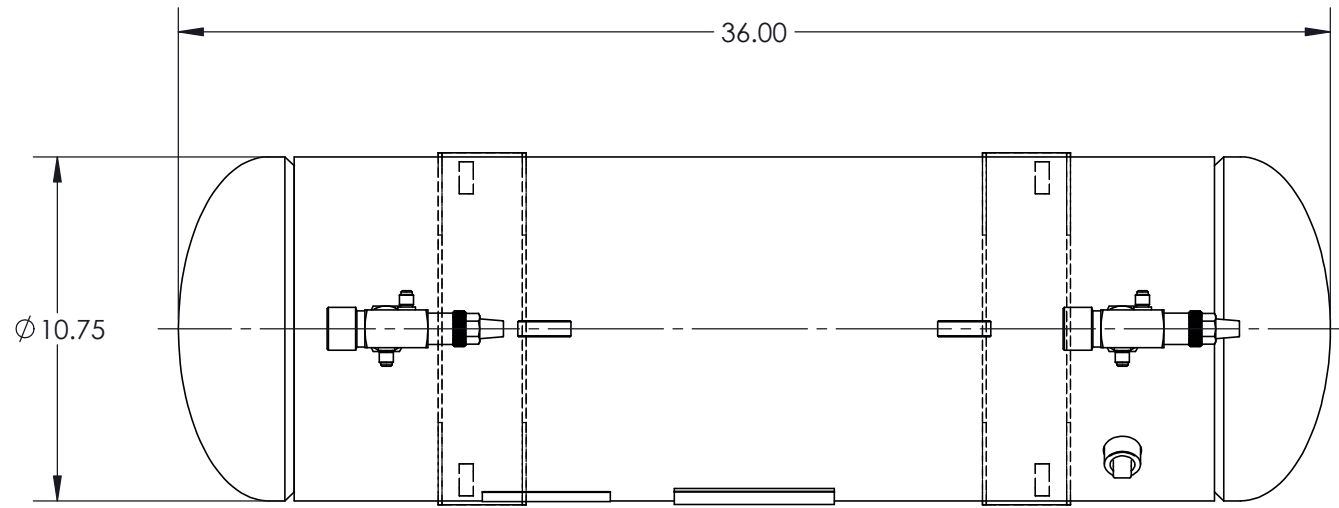

- NOTES:
1. MAX WORKING PRESSURE = 450 PSIG.
 2. DESIGN TEMPERATURE = -20°F TO 250°F
 3. FINISH: BLACK PAINT
 4. ROTALOCK VALVES (2) & GASKETS (2) TO BE BAGGED SEPARATELY & INSERTED IN CARTON WITH UNIT.
 5. INTERNAL VOLUME: 1.614 CUBIC FEET

TOLERANCES UNLESS OTHERWISE SPECIFIED
 0.000 = ±.005, 0.0/0.00/0.00 = ±.063,
 ANG = ±2°, [0.00] = REF

3RD ANGLE PROJECTION

COMMENTS:

PROPRIETARY AND CONFIDENTIAL
 THE INFORMATION CONTAINED IN THIS DRAWING IS THE SOLE PROPERTY OF HENRY TECHNOLOGIES. ANY REPRODUCTION IN PART OR AS A WHOLE WITHOUT THE WRITTEN PERMISSION OF HENRY TECHNOLOGIES IS PROHIBITED.

NEXT ASSY.:	SIM. TO:	
STOCK SIZE:	MATERIAL:	
SIZE: 10-3/4" X 36"	WEIGHT: 96.144 LBS	
DESCRIPTION: HORIZONTAL RECEIVER 10-3/4" X 36"		
SHEET: 1 OF 1		
SCALE: 1:6		
DRAWN: NT		
DATE: 9/6/2024		
APPROVED:	DRAWING NO./PART NO.:	REV:
	S-8690V-CUST	-

Other: H:\ASSYS\

8 7 6 5 4 3 2 1